

OPERATION AND MAINTENANCE DOCUMENTATION HEATER CONDENS

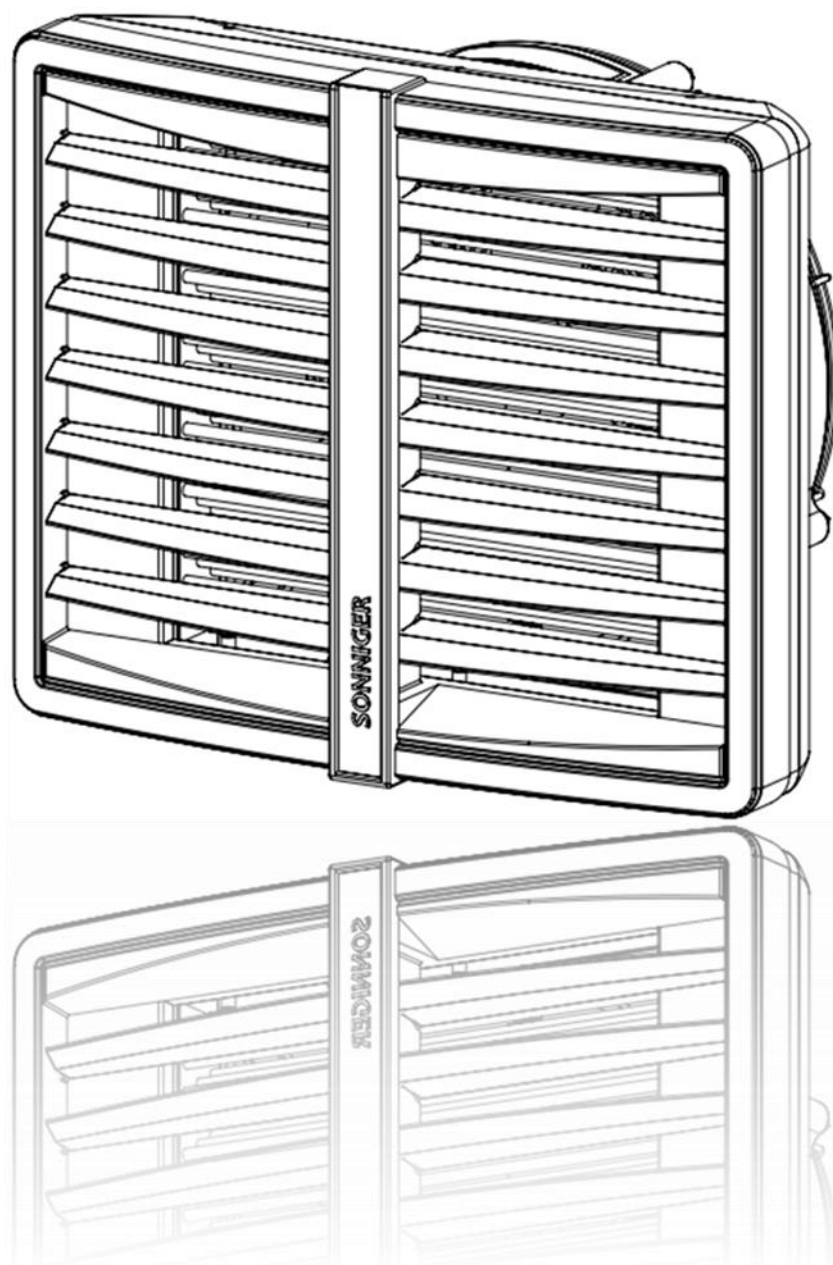

 **SONNIGER**
HEATING PARTNERS

SONNIGER Polska Sp. z o.o. Sp. K.
ul. Śląska 35/37, 81-310 Gdynia, Poland, infolinia 801 055 155, tel. + 48 58 785 34 80, www.sonniger.com

Sąd Rejonowy Gdańsk-Północ, VIII Wydział Gospodarczy Krajowego Rejestru Sądowego, KRS 0000504509,
NIP 586 227 35 14, Regon 22154369 kapitał zakładowy: 1.655.000 PLN

1. OVERALL INFORMATION

HEATER CONDENS heating and ventilation devices are designed to be applied in the buildings of small and medium capacity, especially such as: production and warehouse halls, car showrooms and service stations, sports halls and stadiums, sacral buildings and churches, retail stores and wholesales outlets, agricultural facilities, exhibition surfaces. HEATER CONDENS is a special, dedicated solution to be connected to low water temperature sources (for ex. condensing boilers, industrial heat pumps). Main advantages of HEATER CONDENS are: **high temperature of exhaust air generated** by low temperature of water supplied to a unit, **maximum use of water coil surface** – new geometry of coil construction (enhanced fins size, lower space between fins), **optimized air flow exhaust** – in effect high air exhaust temperature generated on each speed of fan.

2. DIMENSION AND BASIC TECHNICAL PARAMETERS HEATER CONDENS CR ONE

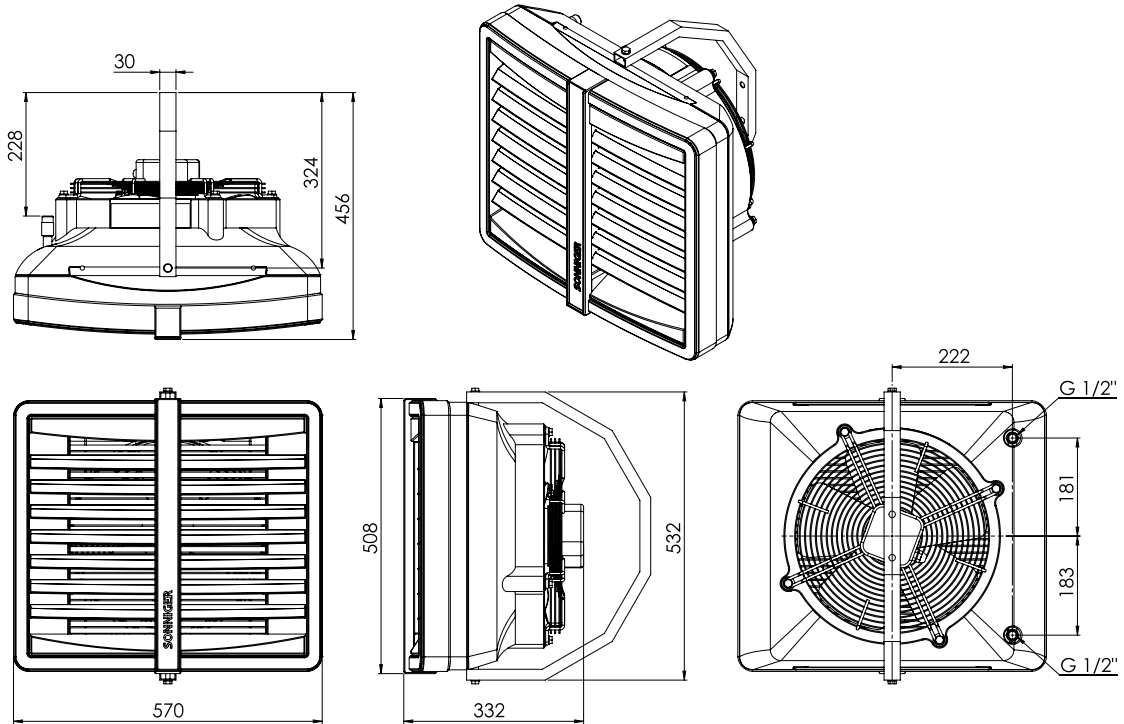

DIMENSION AND BASIC TECHNICAL PARAMETERS HEATER CONDENS CR1, CR2, CR3, MIX1

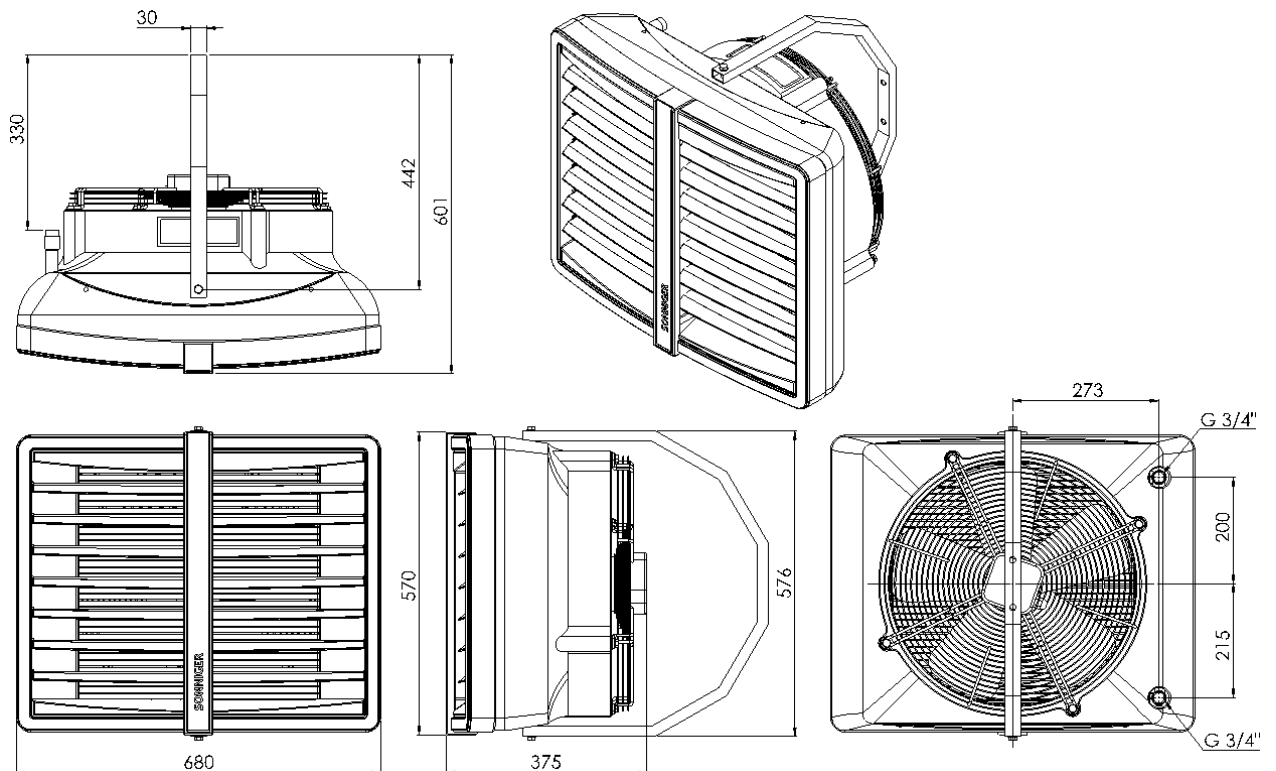

DIMENSION AND BASIC TECHNICAL PARAMETERS HEATER CONDENS CR2 MAX, CR3 MAX, CR4 MAX, MIX2

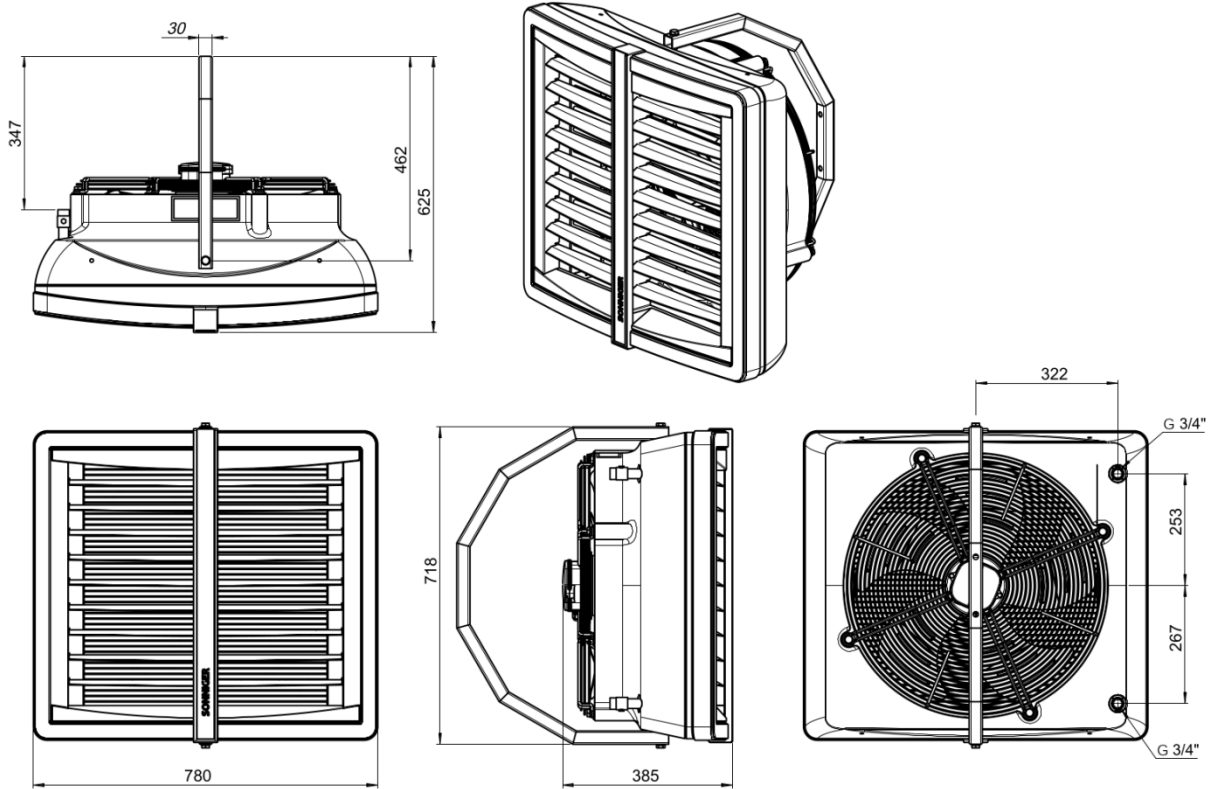

Elements of the HEATER CONDENS devices

- ▤ Casing made of highly resistant EPP (expended polypropylene) material
- ▤ Regulated louvers
- ▤ 3 step axial fan 350 mm, 450 mm or 550mm dimension; protected from direct access to revolving elements with safety netting
- ▤ Heat exchanger – (Cu/AL) made of copper tubes placed in an aluminium lamellar exchanger /block with stub connection 1/2", 3/4". Stub connections are equipped with air-release valves and water agent release

TECHNICAL PARAMETERS	HEATER CONDENS							DESTRATIFIER		
		CR ONE	CR1	CR2	CR3	CR2 MAX	CR3 MAX	CR4 MAX	MIX 1	MIX 2
Suggested heat output range*	kW	5-25	10-35	15-50	20-70	25-70	35-95	40-120	-	-
Heat output (90/70°C) / ΔT air temperature increase**	kW / °C	19 kW/35°C	23 kW/18°C	39 kW/33°C	50 kW/48°C	55 kW/30°C	74 kW/49°C	94 kW /60°C	-	-
Heat output (70/50°C) / ΔT air temperature increase**	kW / °C	13 kW/25°C	16 kW/13°C	26 kW/22°C	35 kW/34°C	40 kW/22°C	53 kW/35°C	68 kW/44°C	-	-
Heat output (50/30°C) / ΔT air temperature increase**	kW / °C	7 kW/15°C	9 kW/8°C	13 kW/11°C	20 kW/20°C	25 kW/14°C	32 kW/21°C	42 kW/27°C	-	-
Max air output - III speed	m ³ /h	1 600	3 900	3 350	2 950	5 700	5 600	5 100	4 800	7 200
Sound level I/II/III speed****	dB (A)	35/46/52	44/52/62	41/50/60	39/48/60	41/50/59	40/48/58	40/48/58	36/44/54	31/42/49
Number of unit rows		2	1	2	3	2	3	3	-	-
Max working pressure	MPa	1,6		1,6						1,6
Max airflow range *****	m	14	24	21	19	26	25	23	13***	16***
Diameter of connection nozzles	inch	1/2"		3/4"			3/4"		-	-
Power supply	V/Hz /A	230/50 0,58A		230/50 1,08A			230/50 2,2A		230/50 1,08A	230/50 2,2A
Motor power	W	124		250			520		250	520
Motor speed	RPM	1400		1350			1380		1350	1380
Protection class IP		IP 54		IP 54			IP 54		IP 54	
Weight without water/with water	kg	9,6/10,7	10,8/11,9	12,7/14,8	14,5/16,9	23,6/25,2	25,2/27,4	25,5/28	9,2	15,8

* presented heat output for water agent temperature range 50/30°C – 120-90°C, air inlet temperature 0°C, III speed.

** for air inlet temperature 0°C

*** max height of installation for vertical airflow, max working area 380 m² for HEATER MIX 1 and 450 m² for HEATER MIX 2

**** measured in distance of 5m

***** Horizontal range of isothermal steam at velocity of 0,5m/s

3. GENERAL INFORMATION

HEATER CONDENS heating and ventilation devices are manufactured in compliance with standards concerning quality, ecology, utility and work comfort. HEATER CONDENS devices are delivered ready-to-use in a cardboard package that is to protect from mechanical damages. The package consists of: the device, the Manual (Operation and Maintenance Documentation) and Guarantee. If the optional automatic control ordered, it shall be delivered in a separate package. Make sure all the aforementioned elements are in the package immediately after the delivery. In the absence of any element, please fill in the suitable carrier document.

ATTENTION !

- ❶ Before mounting read the manual carefully and adhere to the rules concerning the mounting procedures. Not applying may result in inappropriate functioning of the device and the loss of the guarantee rights.
- ❶ Pay special attention when working with electrical elements of the device.
- ❶ Any installation operations must be carried out by qualified persons with appropriate authorizations

4. ASSEMBLY

Prior to any installation procedures, take the following aspects into consideration: easy access for maintenance works, access to water and electrical installation, appropriate air distribution in a room.

Each HEATER unit is equipped with a set of 2 interchangeable colour inserts; in order to change the color, remove the insert from the front panel and place the desired one back in place.

It is advisable to mount the device to the wall or the ceiling on original mounting brackets, supporting mount pins (not delivered with the device) or supporting constructions (shapes and dimensions of the supporting construction may be individually designed in compliance with durability and strength requirements).

In case of mounting to the ceiling, pay attention to the fact that air-release/venting of the device may be difficult so it is advisable to place vent at the highest point of the pipework.

The device may be mounted to the wall with the use of a mounting bracket at the angle of 0°, 30° or 60°. A mounting bracket holder is made of curved profile. It has two holes for vertical assembly. Assembly to the wall and/or to the ceiling is possible at different angles but it requires making necessary holes in the holder.

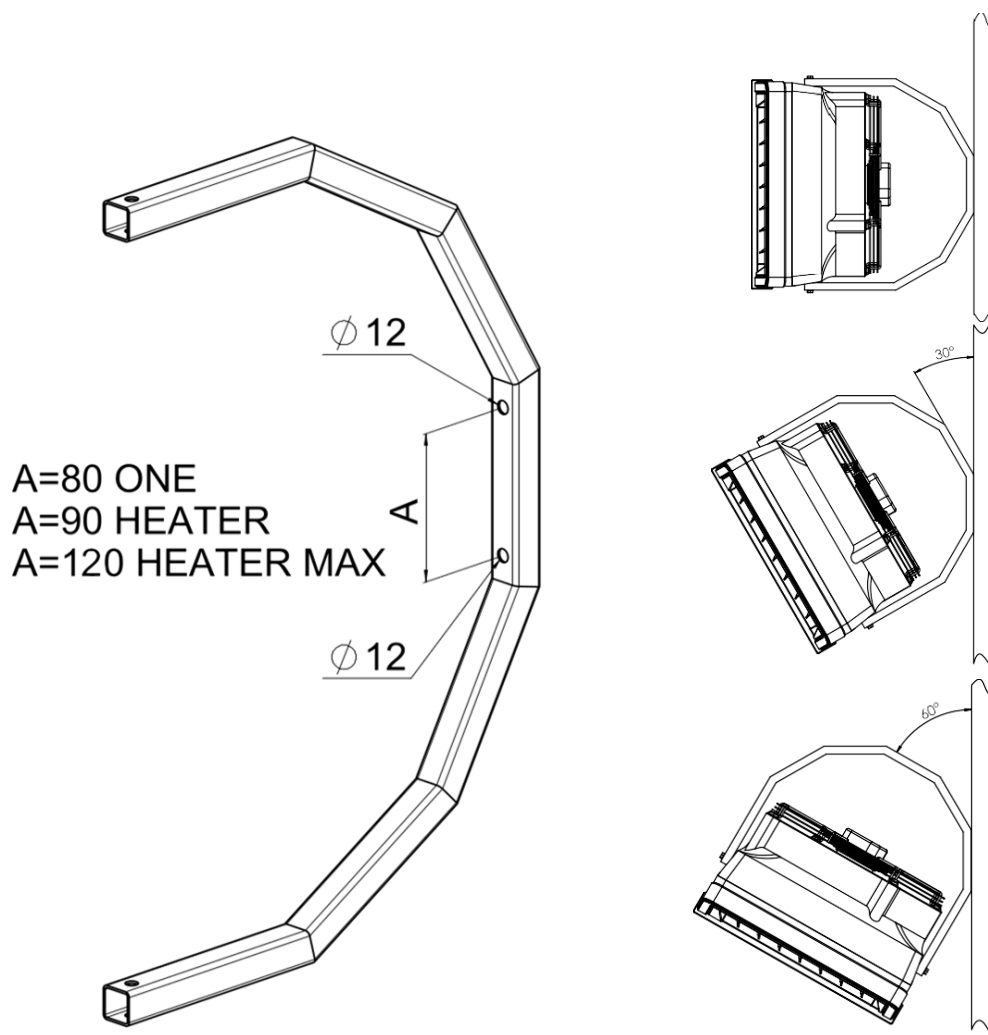

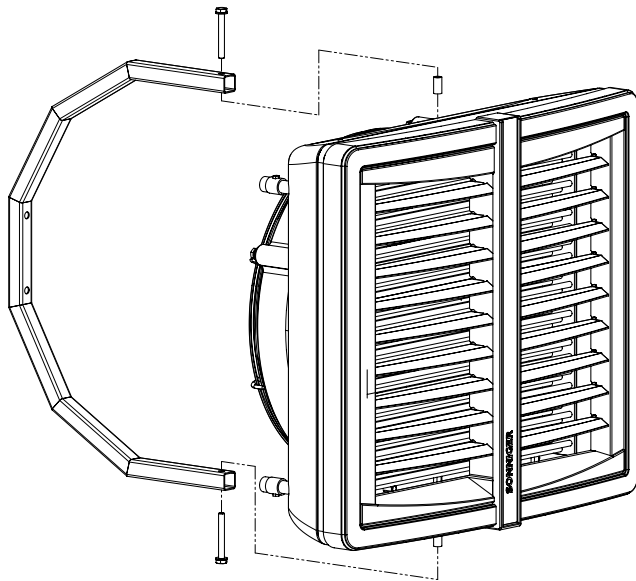

Mounting bracket to the heater

The bracket set consist of: a holder, two sleeves, two M8 screws and washers. In order to mount the bracket, drill two Ø12-13mm holes in places visibly marked on the casing. Insert sleeves into drilled holes and place the bracket in. The included holder must be screwed with M8 screws with washers.

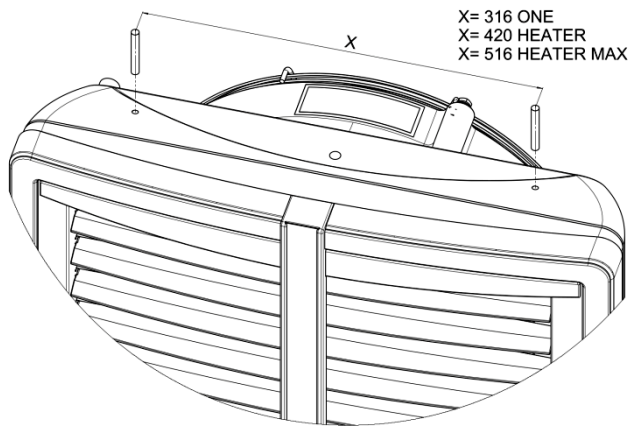

Installation of mounting pins

To mount the heater to the ceiling, use M8 mounting pins. Drill two Ø8-9mm holes in places visibly marked on the casing. Mounting pins may be screwed into the frame not deeper than 20 mm

ATTENTION !

ⓘ While drilling the holes in marked places be careful not to damage the coil by going deeper than 20mm!

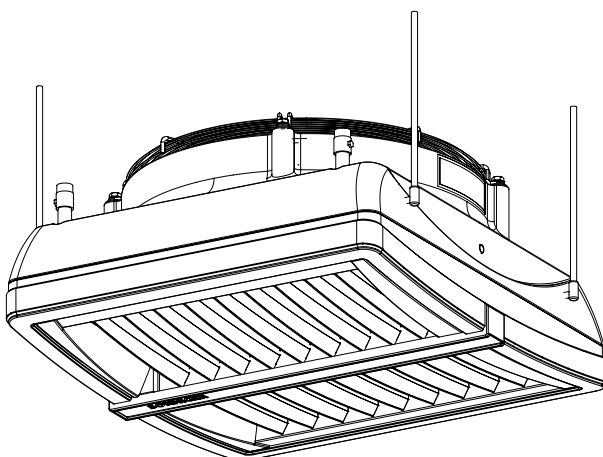

Assembly of HEATER MIX air mixer

To mount HEATER MIX air mixer to the ceiling, use M8 mounting pins. Drill two Ø8-9mm holes in places visibly marked on the casing. Mounting pins may be screwed into the frame of a heat exchanger to the maximum depth of 20 mm. Mounting pins and connecting elements are not included with the unit

NOTICE !

ⓘ To sustain proper functioning of the device keep a safe distance– 200 mm from its sides and 300 mm from its backside (from the fan)

5. ELECTRICAL INSTALLATION

The electrical installation and connection to power supply must be done in compliance with the existing regulations and standards for building industry.

The fan's engine is equipped with the internal temperature limit fuse protecting the engine from its overheating.

The unit set does not consist of: a feeding cable, a master switch (see diagram)

The electrical installation must be done by an authorized person, acquainted with the Manual. The connection of the feeding cable and master switch must be done in compliance with electrical diagram (with or without the automatic control, depending on the option chosen). Any and all damages incurred as a result of the aforementioned causes are not provided with the Guarantee and the user will be charged with any costs of the device exchange. The connection of the automatic control should be carried out in accordance with the electrical diagram.

In case of any doubts or problems, unplug the device and contact the device's installer or SONNIGER Authorized Service.

6. WATER INSTALLATION

The installation of the unit should be done in a way enabling maintenance service; on both stub pipes manual closing valves should be installed in order to cut off the device. Feeding cables of the heater shall be connected in accordance with the symbols/markings on the casing (inlet/outlet). In case of electromagnetic valve (with the option of the automatic control) it should be installed on the outlet as it may be damaged otherwise. When the pipework is being connected to the exchanger, secure the connections of the heater from oscillating torque (see figure) that may cause leakage in the exchanger.

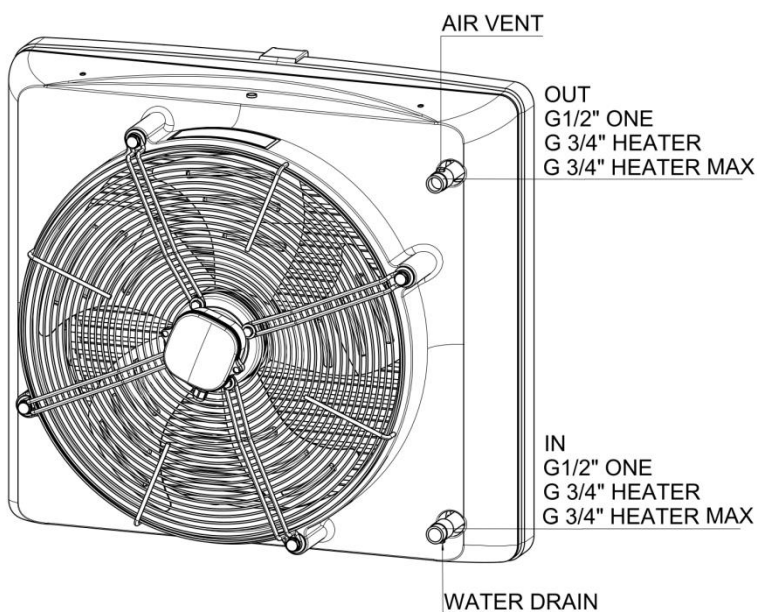

Heating medium

The connector pipes are at the back of the device. When connecting the hydraulic pipes/connections, make sure you secure the connector pipes against rotational torque. Notice that the connector pipes are not strained by the pipes. The valve of heating medium is on the supply pipe and the vent is on the return pipe.

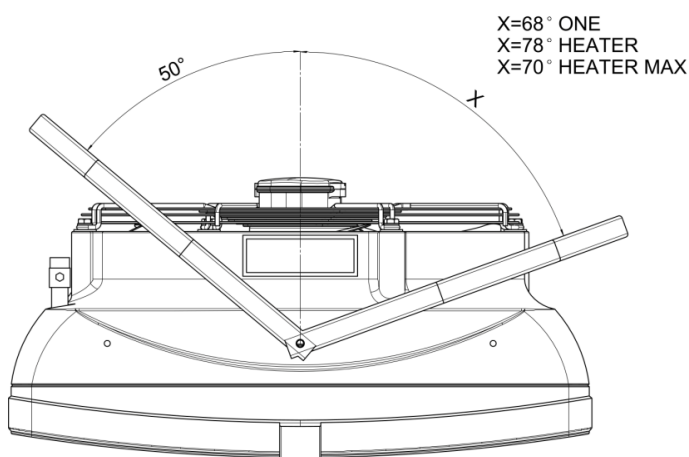

Use flexible connections to allow the heater to be turned to the sides. Depending on the flexible connections, the maximum turn is 70° - for HEATER CONDENS MAX, 78° - for HEATER CONDENS CR1, CR2, CR3, 68° - for HEATER CONDENS ONE, to both sides. Figure shows maximum angle to one side and 50° to the other with minimal distance left for connections.

7. AUTOMATIC CONTROL - INSTALLATION

A set of automatic control may be used (powered 230V) that consists of the following:

- COMFORT panel – including room thermostat and switch for regulation of 3 speeds of fan. One COMFORT panel may regulate up to 6 pcs of HEATER CONDENS CR ONE, 3 pcs of HEATER CONDENS CR1,2,3 units or 2 pcs of HEATER CONDENS MAX
- 2-way water valve with actuator; valve should be installed on a return stub of the heater
- INTELLIGENT electronic control panel with an automatic speed controller, weekly program and BMS communication. One INTELLIGENT panel may regulate up to 2 pcs of HEATER CONDENS units or for single HEATER CONDENS MAX
- Splitter MULTI 6 - control up to 6 pcs of HEATER CONDENS, HEATER CONDENS MAX or 12 pcs of HEATER CONDENS ONE units from one COMFORT or INTELLIGENT Panel

The system is ready to start once the connections between the thermostat and the valve actuator are done, 230V power is supplied to the thermostat and the fan's motor is powered by the revs controller.



COMFORT panel description

ON/OFF – turning ON/OFF a unit

I-II-III – switch for fan speed regulation

HEAT - thermostat sends signal for valve and actuator and fan, fan turns off when temperature in room is achieved, valve/actuator closes water supply.

FAN – function not active, unit will not operate when FAN switch is selected

COOL – thermostat sends signal only to fan and to the servo of the valve, fan begins operation starting from temperature which is set on thermostat (function used to air mixer HEATER MIX or for room ventilation in summer season)

8. FIRST START

Do all the connections (electrical, water and automatic control), check for tightness of all connections done by an installer and air-release/vent the device then start the device in the following sequence:

1. Switch on the mains,
2. Set requested speed of fan on revs controller,
3. Set requested temperature on thermostat,

The fan operates continuously irrespective of whether the heater's valve is opened or not.

9. TURNING OFF

To switch the device off do the following:

1. Set minimum temperature on thermostat – after 7 seconds valve will be closed and heating switched off.
2. Set main switch to the "0" position (off); fan will be switched off and the thermostat will be off the power.

10. OPERATION

The engine and fan used in HEATER CONDENS units are maintenance-free devices but regular check-ups are advised, especially motor and bearing (fan's rotor should rotate freely, free from any axial and radial throws and undesired knocks/rattles).

NOTICE !

- ⓘ In case of any metallic knocks, vibration or increase in sound level check if the fan mounting/fixing does not work loose contact the installer or SONNIGER Authorized Service

11. MAINTENANCE

The heat exchanger requires systematical cleaning all dirt/impurities off. Before the start of the heating period the heat exchanger is advised to be cleaned with compressed air directed to the air outlets; there is no need for dismantling of the device. Pay special attention when cleaning the exchanger's fin due to high possibility of damaging them. If fins are bent use a tool specifically designated to carry out such repairs. If the device has not been used for a longer period of time, unplug it before the next use. The heat exchanger is not equipped with any fire protection device. The heat exchanger may be damaged if the room temperature goes below 0 C.

Anti-freeze liquid must be added to the water circulation/system. Anti-freeze liquid must be appropriate for the material the exchanger is made of (copper) as well as other elements of the hydraulic system/circulation. The liquid must be diluted with water according to the solution recommended by the anti-freeze manufacturer.

13. ELECTRICAL CONNECTION DIAGRAMS

13.1. Connecting HEATER CONDENS with no automatic control

* The unit set does not consist of: a master switch, a fuse, a feeding cable

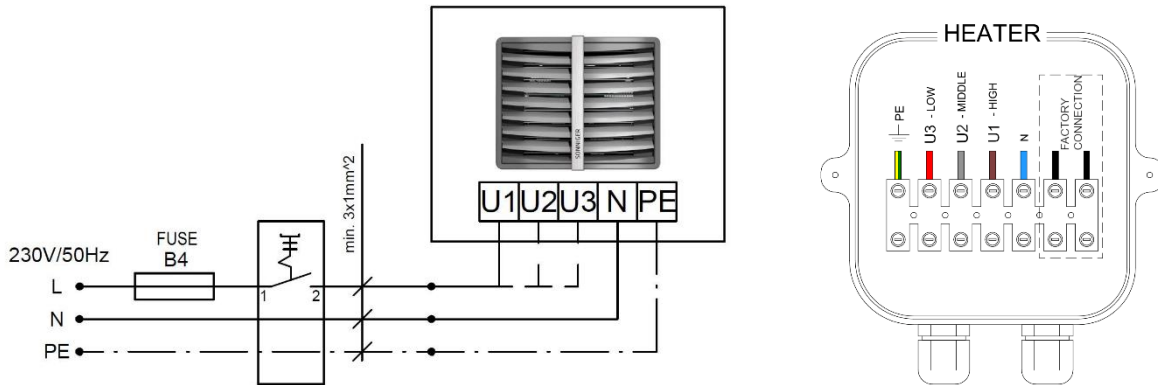

Fan wiring description

- U1** high speed – brown
- U2** middle speed – grey
- U3** low speed – red
- N** neutral – blue
- PE** protection - yellow/green

13.2. Connecting several HEATER CONDENS units with COMFORT panel, valves and actuators

One COMFORT panel may regulate up to:

- **6 pcs** of HEATER CONDENS CR ONE
- **3 pcs** of HEATER CONDENS CR 1,2,3
- **2 pcs** of HEATER CONDENS MAX

* The unit set does not consist of: a master switch, a fuse, a feeding cable

HEAT - thermostat sends signal for valve/actuator and fan, fan turns off when temperature in room is achieved, valve/actuator closes water supply.

FAN – function not active, unit will not operate when FAN switch is selected

COOL – thermostat sends signal only to fan and the servo of the valve, fan begins operation starting from temperature which is set on thermostat (function used to air mixer HEATER MIX or for room ventilation in summer season)

Attention! You can use additional jumper on the contacts 4-5 of COMFORT Panel, in this case you may only use function of changing speed of fan I-II-III and ON / OFF. The thermostat and switches HEAT / FAN / COOL remain not active.

Additional jumper on terminals 4-5 might be applied when for ex different (supplied by user) thermostat is used to control the system.

In that case:

- motor would be working on set speed
- thermostat open/close the servo of the valve depending on set temperature

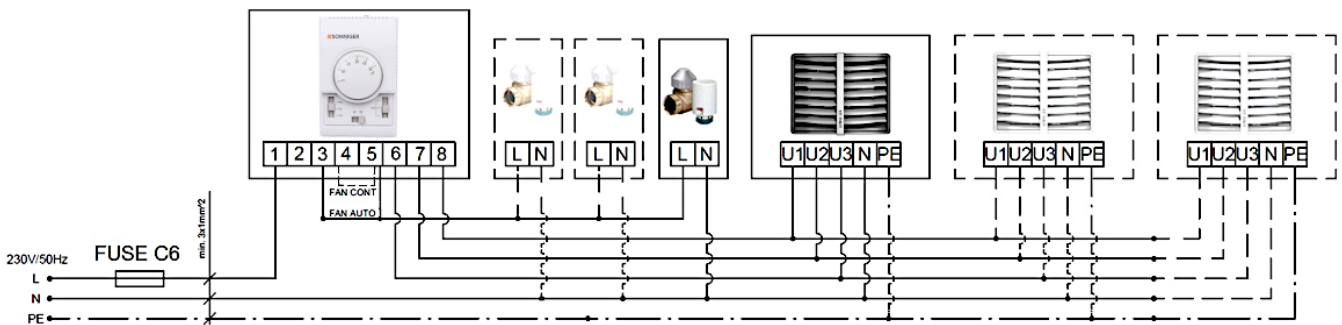

13.3. Connecting HEATER CONDENS with panel INTELLIGENT.

Panel Intelligent controls actuators/valves and automatically regulates fans' speed depending on the required room temperature. Fans speed changes automatically for lower rate, when temperature in a room gets closer to desired one.

Additional functions – weekly thermostat, availability of BMS communication signals

Possibility to connect outside temperature sensor NTC, supplied with cable length 5 m, max cable length 20 m.

One INTELLIGENT panel may regulate:

- **up to 4 pcs** of HEATER CONDENS CR ONE
- **up to 2 pcs** of HEATER CONDENS.
- **only 1 pcs** of HEATER CONDENS CR MAX

* The unit set does not consist of: a master switch, a fuse, a feeding cable

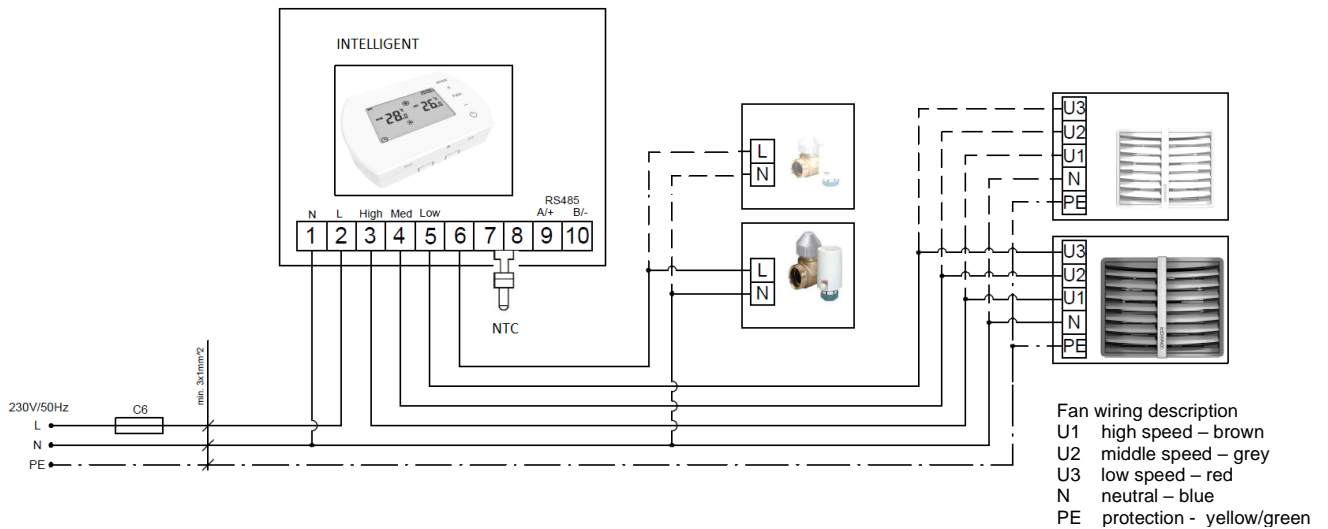

13.4. Splitter MULTI 6 - control up to 6 pieces of HEATER CONDENS / HEATER CONDENS MAX or 12 pcs of HEATER CONDENS CO ONE from one COMFORT or INTELLIGENT Panel

MULTI 6 Splitter allows to connect and control more fan heaters (up to 6/12 pcs.) and valves with actuators (up to 6/12 pcs.). Control of fans and valves is done using COMFORT or INTELLIGENT panel.

To connect more than 6 fans and valves, it is possible to connect Splitter MULTI 6 with each other (maximum extension of up to 10 MULTI 6 splitters). In such case, in the first Splitter MULTI 6 there should be connector DS-N left open, in other Splitters MULTI 6 (2..10) connector DS-N must be closed.

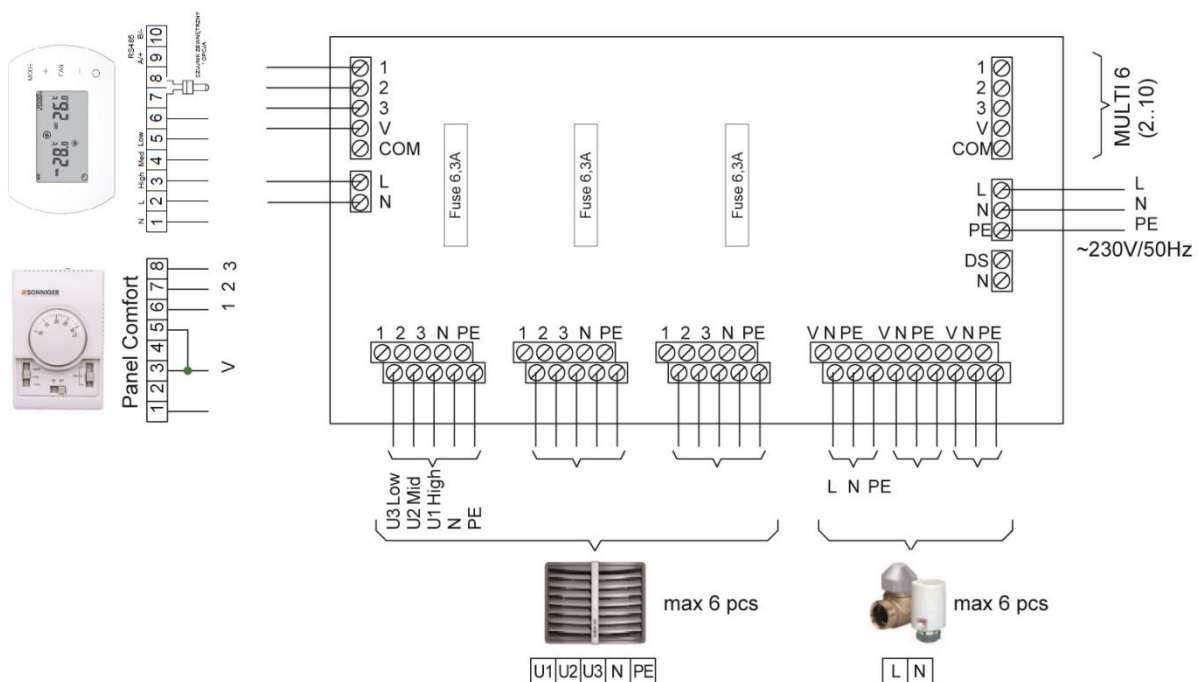

14. PANEL INTELLIGENT – programmable controller manual

Panel Intelligent controls actuators/valves and automatically regulates fan's speed depending on the required room temperature. The lower temperature in the room the higher air output is set. Fans speed changes automatically for lower rate, when temperature in a room gets closer to desired one

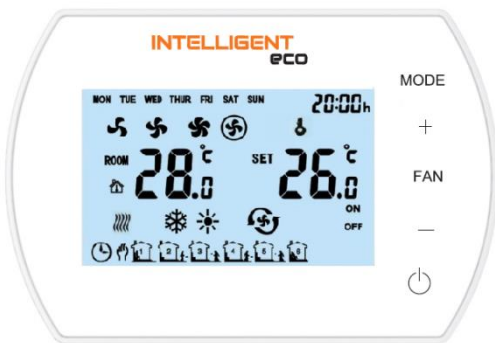

Functions

Panel INTELLIGENT is designed for the SONNIGER products

- Weekly thermostat (5/1/1 days)
- Automatic or manual 3-step fan speed adjustment.
- Control room temperature (by opening/closing the valve, or by adjusting air volume automatically).
- Antifreeze mode- protection against dropping room temperature below critical level 5 ~ 15 °C.
- Possibility to connect external NTC temperature sensor.
- BMS communication by MODBUS protocol

Panel description

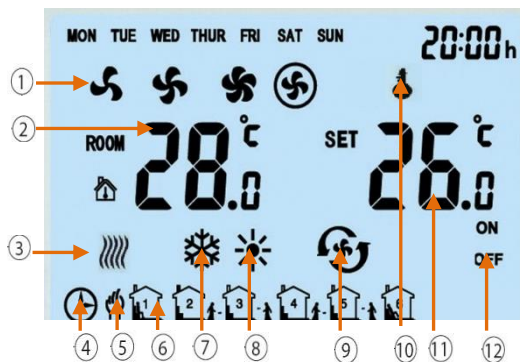

1. Fan Speed: LOW, MED, HI and AUTO
2. ROOM TEMP. or NTC EXTERNAL SENSOR TEMP. (measured temperature)
3. Anti-freeze indication
4. Automatic programable mode
5. Manual mode
6. 6 Time Zones for each day
7. Cooling Mode
8. Heating Mode
9. Ventilation Mode
10. Buttons Lock
11. SET TEMP. (desired room temperature)
12. ON/OFF status of time zones



13. MODE
Press shortly to select manual or automatic mode
Press and hold for 3 s and select colling, heating or ventilation mode
14. FAN
Press shortly and select fan speed: Low, Med, High or Auto
15. ON/OFF INTELLIGENT Panel

Technical parameters

1	Power supply	230VAC/50Hz
2	Temperature setting range	5°C 40°C
3	Temperature working range	-10°C 60°C
4	IP class	20
5	Temperature sensor	Internal / external NTC (optional)

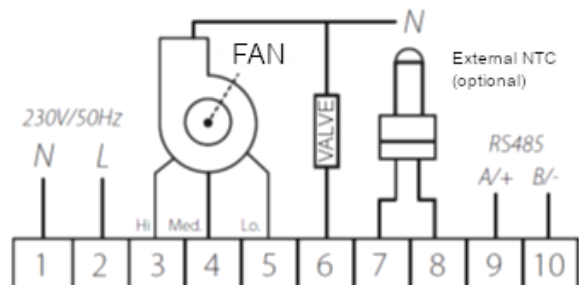

WARNING!

RISK OF ELECTRICAL SHOCK. Disconnect power supply before making any electrical connections. Contact with components carrying hazardous voltage can cause electrical shock and may result in severe personal injury

Dimensions

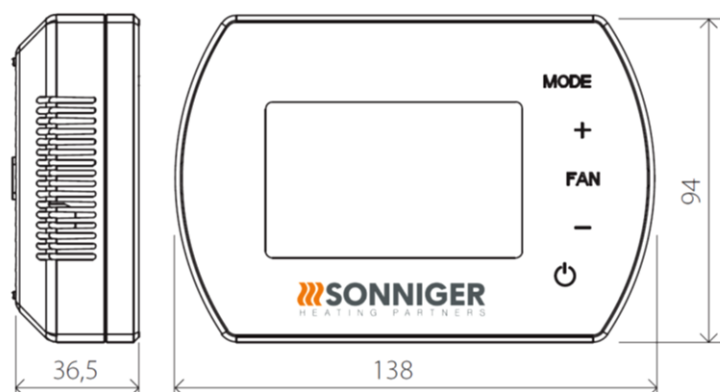

Settings menu

When Panel Intelligent is switched off, press and hold MODE for 5 seconds

To change option use MODE button.

To change value use +/- buttons.

Setting menu	Option	Value
1	Temperature calibration	-9°C ~ +9°C
2	Fan status	C1: Thermostatic mode C2: Continuous mode
3	Temperature sensor	0: Internal Sensor 1: External Sensor NTC (optional)
4	Antifreeze	0: Off 1: On
5	Antifreeze range	+5°C ~ +15°C
6	BMS speed	0-2400 / 1-9600 / 2-19200
7	Modbus ID	1~247 (01~F7)

Button lock / unlock



To LOCK buttons press and hold + and then – and hold both of them for 5 seconds.

To UNLOCK buttons press and hold + and then – and hold both of them for 5 seconds.

Press MODE

Change on manual mode  or automatic mode 

Hold MODE for 5 seconds

Change to cool mode , heating mode , ventilation 







Press FAN

Change of the fan speed low , medium , high , automatyczna 

Hold FAN for 5 seconds

Manual calendar programming Monday – Friday, Saturday, Sunday 6 settings per day

BMS Functions

-  Setting/Reading work parameters
-  Work/Stop conditions
-  Weekly program
-  Temperature
-  Fan speed
-  Heating , ventilation, cool mode
-  Antifreeze mode

No.	Setting	Parameters
1	Working Mode	RS485 Semi-duplex; PC or main controller is master; thermostat is slave
2	Interface	A(+),B(-), 2 wires
3	Baud Rate	0-2400 / 1-9600 / 2-19200
4	Byte	9 bits in total: 8 data bit + 1 stop bit
5	Modbus	RTU Mode
6	Transmittion	RTU (Remote Terminal Unit) format (please refer to MOBUS instruction)
7	Thermostat address	1–247 ; (0 is broadcast address and stand for all thermostat without response)

COMPLIANCE WITH WEEE 2012/19 / EU

In accordance with applicable legal regulations, at the time of purchasing new electrical or electronic equipment with the following mark:



REMEMBER IT IS FORBIDDEN TO PLACE THE WORN EQUIPMENT WITH OTHER WASTE

For information on the waste collection system of electrical and electronic equipment, please contact your distributor

GUARANTEE TERMS AND CONDITIONS

§1 Guarantee Scope

1. The Guarantee entitles the Buyer to have the device or its part replaced with the faultless one only if within the Guarantee period the Manufacturer claims that a disclosed defective product or part cannot be repaired.
2. The proof of purchase and a correctly completed complaint form must be delivered to demand repairs with no additional costs.
3. This Guarantee covers material defects of the device which make its functioning impossible. This Warranty does not extend to the installation and maintenance works.
4. The Guarantee for the product sold by the Seller covers 24 months. The guarantee period commences upon delivery of the device to the Buyer specified in the sales invoice. The warranty covers any and all parts/components specified in the scope of the delivery.
5. Products delivered by third persons are guaranteed by this supplier.
6. Devices may be started and serviced only by qualified persons trained in the areas of maintenance and operation of the device. Any and all operations related to start, maintenance and repairs must be noted that such operations have occurred in the Guarantee Card.
7. The precondition for issuing the Guarantee by the manufacturer is the assembly and activation of the device in accordance with the Operation and Maintenance Documentation not later than 6 months after the date of purchase.
8. The product is guaranteed for a full period of warranty only if service works implied in the Operation and Maintenance Documentation for the device specified in the 'Maintenance' section are carried out. All services related to the maintenance of the device are carried out at the User's cost and expenses.
9. The provision of warranty services does not cease or suspend the duration of the Warranty. The warranty for replaced or repaired parts/elements shall end with the expiry of the Guarantee for the device.

§2 Warranty Exclusions/Disclaimers

1. The Warranty does not extend to the mechanical damages and damages to electrical parts caused by improper use, transport, abnormal voltage or other damages arising from a product defect. For the above reasons, the Warranty is solely limited to the replacement of parts/components having construction defects that shall be delivered without any additional costs only if the defective part/component has been returned.
2. The Warranty for devices does not apply to when technical mistakes occurred during the procedures concerning installation, regulation and controlling including any of the following:
 - a) Defects caused by connecting a device to an inappropriately designed ventilation system that allows additional heat loads that do not meet any standards and decrease the efficiency of heat exchanger.
 - b) Defects caused by connecting to the components or parts that are part of the heating system but have not been delivered by the Seller and whose inappropriate functioning has a negative impact on the device's functioning.
 - c) Defects caused by connecting to the components that are not original spare parts
 - d) Defects incurred by reselling of the product by the first buyer/user to another buyer who dismantles/installs the device that was previously installed and operated in a specific building and its conditions.
 - e) Defects caused by an improper expertise and insufficient knowledge of the installer and technical staff who, in an improper way carry out after-sale service of the device
 - f) Defects caused by special conditions of use that differ from typical/standard applications unless the parties (the Seller and customer's technical staff) have previously agreed otherwise in writing.
 - g) Defects incurred by natural disasters such as fire, explosions and other incidents that may result in damages to mechanical, electrical and protection devices
 - h) Defects caused by inappropriate cleaning of the technical facility or place where the device has been installed; cleaning must take place periodically to suit the specific working conditions and the amount of dust.
 - i) Defects arising from the absence or improper cleaning of heat exchangers; cleaning must be done periodically to suit the specific working conditions and the amount of dust.
 - j) Defects incurred by the inappropriate installation inadequate for low outside temperature of working conditions.
 - k) Defects incurred by low temperature if no protection device is installed by the installing contractor to avoid:
 - low temperatures on electrical and mechanical parts such as valves, electric and electronic controlling devices,
 - water condensation and frost/ice near the device,
 - thermal shock of the heater and heat exchanger caused by sudden changes of outside temperature.

§3 SONNIGER is not liable to:

1. Current maintenance works, inspections following from Operation and Maintenance Documentation and device programming.
2. Defects caused by banking of a device while waiting for the warranty service.
3. Any and all defects caused to the company's property.

§4. Complaint Procedure

1. In the event of the complaint under the Warranty conditions the user may make lodge a complaint directly to the Distributor.
2. All repairs covered by the warranty shall be done as part of the activity of an installation company and Factory Service. All repairs ensuing from the guarantee shall be done in a place where the device is installed.

3. The user with respect to the service activities is obliged to:
 - Allow to have full access to the rooms where the devices were installed and provide the necessary facilities allowing direct access to the device (lift, scaffolding etc.) in order to do all the servicing covered by the guarantee.
 - Present the original of the Guarantee Card and VAT invoice recording the purchase,
 - Ensure the safety while doing the servicing,
 - Allow to start works immediately after the arrival of the Service.
4. In order to make a complaint under the warranty it is necessary to deliver to the Distributor's address the following documents:
 - a. a correctly filled-in complaint form that is available at the website of www.SONNIGER.com
 - b. a copy of the Guarantee Card
 - c. a copy of the proof-of-purchase - the sales invoice
5. Repair service including the replacement of the parts shall be done free of charge only if the representative of the installing contractor or the Service claim that the defect or faulty device is caused by fault of the producer.
6. Any and all costs (cost of repair, travel and exchanged components) incurred due to the unjustified complaint especially in the situation when the representative of the Installing Contractor of the Factory Repair Service claims that defect/damage was caused as a result of breaching the guidelines provided in the Operation and Maintenance Documentation or notices the exclusions under **§2 (Warranty exclusions) will be** requested from the Buyer/Customer who reported the failure.
7. The Claimant is obliged to give a written confirmation of the service provided.
8. SONNIGER is entitled to refuse the warranty service if SONNIGER has not received full payment for the product complained about under the Guarantee or any previous servicing activities.

WARRANTY CARD

INVESTMENT NAME.....

Unit type.....

Unit number.....

Purchase date.....

Startup date.....

Installation company date:

Name of startup Installer:.....

Company name.....

.....

Address:.....

Phone.....

Signature of startup installer.....:

Maintenance and repair registration:

Date	Maintenance and repair description	Stamp and signature of installation company