

Installation Instructions

STANDARD (ACD) MODELS

1 Carefully remove packing from air curtain

2  Check the overall weight of the unit to ensure safe handling and that the structural wall or ceiling supports are sufficient

3 Ensure installation can be performed in such a way that on completion the air inlet and outlet grills are free from obstruction.

Minimum clearance between the ceiling and air inlet grill is 100mm

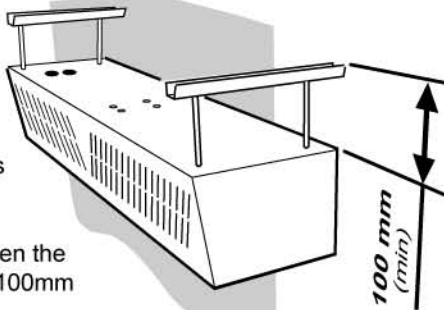

4 Fix the unit securely to the wall, ceiling or floor

- for wall or ceiling mounting, unscrew and remove the front panel (X)

- if floor mounting do not remove front panel (X)

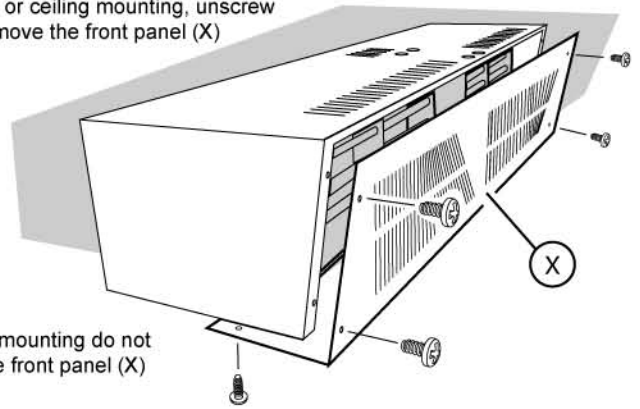

Wall Mount

- refer to the model tables and illustrations on Pages 2 and 3 and drill upper and lower mounting holes
- insert N° 6 screws in the upper holes and mount the unit on them

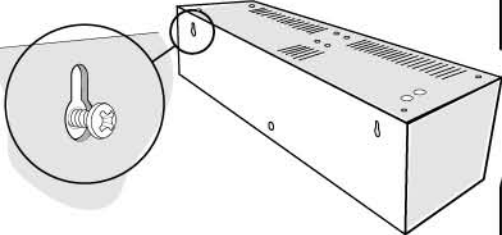

- firmly secure the unit to the wall with a screw in each lower mounting hole

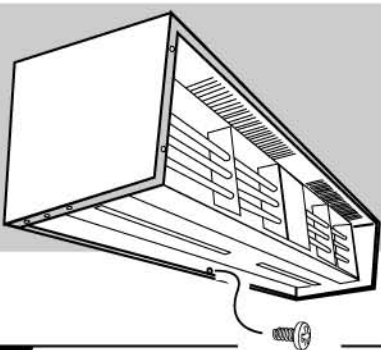

Ceiling Mount

- refer to the model tables and illustrations on Pages 2 and 3, fix drop-rod brackets to ceiling (brackets not supplied)
- insert M8 drop-rods into the threaded holes on the top of the unit

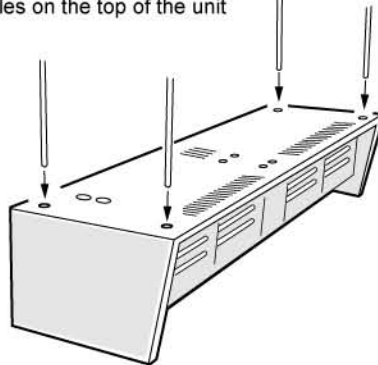

- secure the unit to ceiling brackets and adjust as necessary

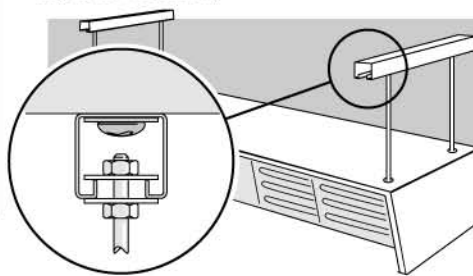

Floor Mount

- refer to the model tables and illustrations on Pages 2 and 3 and drill mounting holes
- secure unit to floor

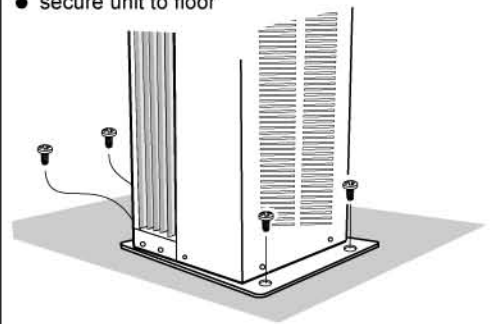

- to prevent accidental damage, use top bracket provided to secure unit to wall



- the cover should now be removed

5 Electrical connections can now be made

Load requirements will vary according to model and whether electrically heated or otherwise. In the case of electrical heaters, these are available in 380/400/415V 3ph only, all other units are 1ph unless specified. Please check relevant circuit diagram when installing. Circuits must be protected with a suitable fuse and the appliance earthed. All electrically heated air curtains are protected with thermal safety cut-outs. these will automatically reset. You must ensure that the electrical cable installed is capable of taking the load indicated on the appropriate wiring diagram or table.



The units should be wired by a competent electrician and be in accordance with the latest I.E.E. wiring regulations

Caution

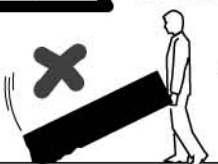

Dynamically balanced fan scroll. Do not subject to impact during unpacking or installation.

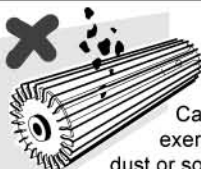

Care should be exercised in preventing dust or solid material from entering the fan scroll.

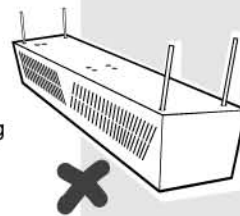

Avoid damage or distortion to the unit, particularly when connecting services.

Fixing Details

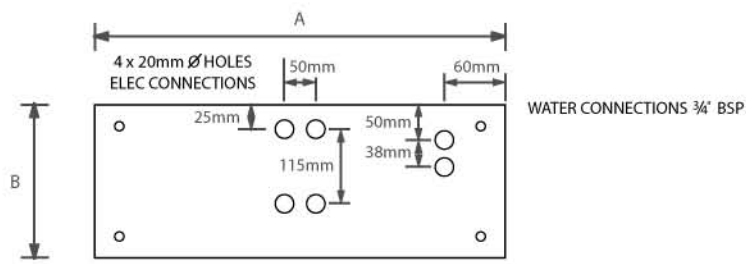

TOP VIEW

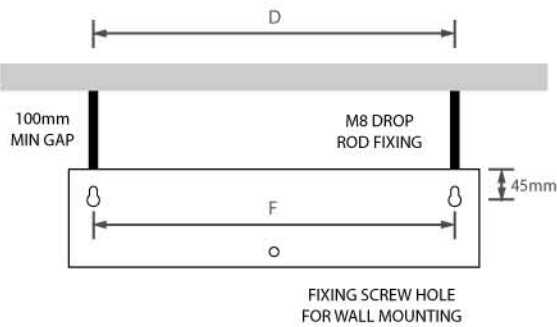

BACK VIEW

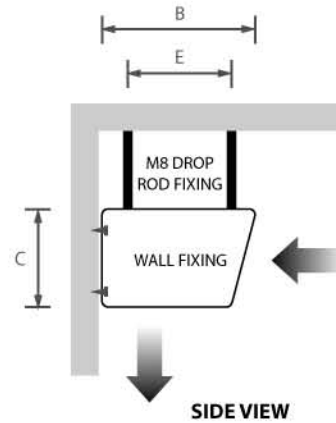
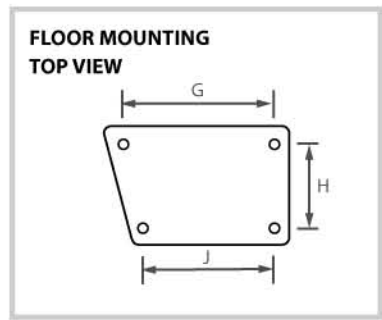

SIDE VIEW

Wiring Diagrams

ELECTRIC HEATING UNITS

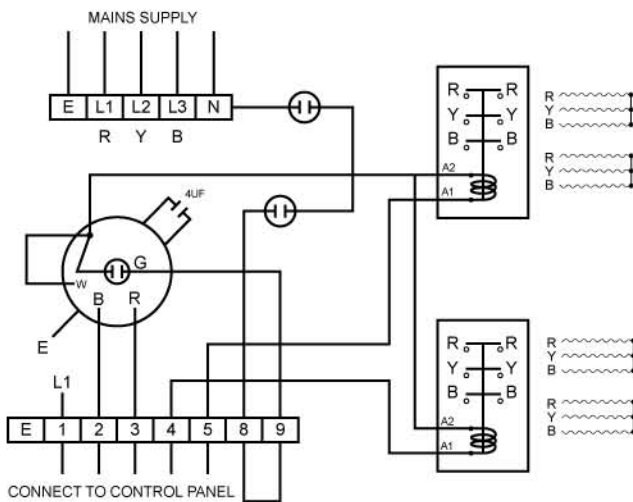

AMBIENT/WATER UNITS

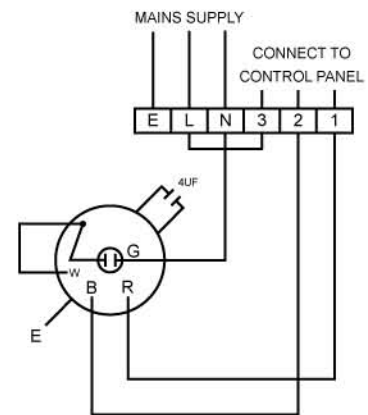

ELECTRIC CONTROL PANEL

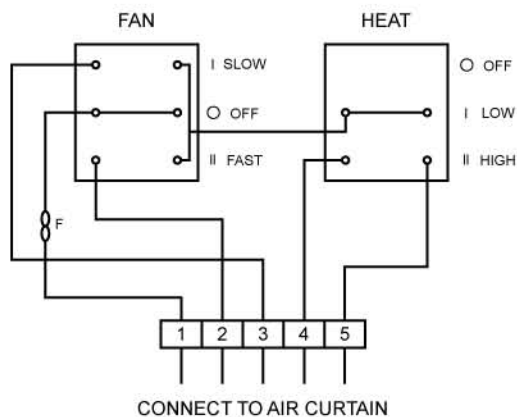

AMBIENT/WATER UNITS CONTROL PANEL

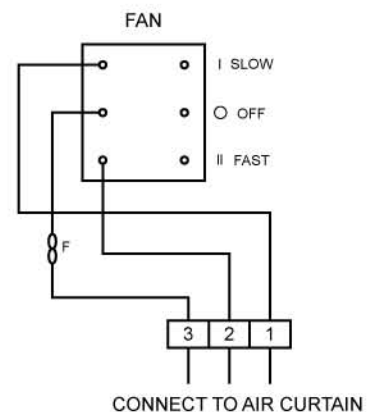

Technical Details

Model	Heat output	Max current	Motor power	Voltage	Max air vol m3/h	Max height	Noise level d(B)A	Weight Kg
ACD 10A	-	0.52A	60W	220/1ph	1490	2.7m	55/52	20
ACD 10W	8Kw	0.52A	60W	220/1ph	1300	2.7m	54/51	24
ACD 10E	7Kw	10A*	60W	380/3ph	1400	2.7m	55/52	23
ACD 15A	-	0.52A	60W	220/1ph	2200	2.7m	56/53	30
ACD 15W	12Kw	0.52A	60W	220/1ph	2000	2.7m	55/52	36
ACD 15E	12Kw	17A*	60W	380/3ph	2100	2.7m	56/53	35
ACD 20A	-	0.52A	120W	220/1ph	2980	2.7m	58/55	40
ACD 20W	16Kw	0.52A	120W	220/1ph	2600	2.7m	57/54	48
ACD 20E	14Kw	20A*	120W	380/3ph	2800	2.7m	58/55	46

*per ph Suitable for 230/400/415V supply.

LTHW at 80/60°C

DIMENSIONS

Model	Unit Dimensions		
	A mm	B mm	C mm
ACD 10A	1100	300	200
ACD 10W	1100	300	200
ACD 10E	1100	300	200
ACD 15A	1600	300	200
ACD 15W	1600	300	200
ACD 15E	1600	300	200
ACD 20A	2200	300	200
ACD 20W	2200	300	200
ACD 20E	2200	300	200

FIXING DETAILS

Model	Unit Fixing Positions					
	D mm	E mm	F mm	G mm	H mm	J mm
ACD 10A	1040	190	1040	320	140	296
ACD 10W	1040	190	1040	320	140	296
ACD 10E	1040	190	1040	320	140	296
ACD 15A	1540	190	1540	320	140	296
ACD 15W	1540	190	1540	320	140	296
ACD 15E	1540	190	1540	320	140	296
ACD 20A	2140	190	2140	320	140	296
ACD 20W	2140	190	2140	320	140	296
ACD 20E	2140	190	2140	320	140	296

For ACD 2 metre fixing details use ACD 10 x 2

Operating Instructions

Air Curtains are supplied with remote control panels as standard. These can either be flush or surface mounted.

Ambient and water heated units have a three position switch giving slow fan speed/ off / fast fan speed.

Electrically heated units are supplied with an extra three position heat switch offering off/ low heat/ high heat.

Each control panel can be used to control single or multiple units.

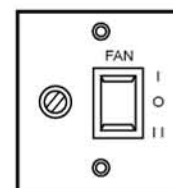
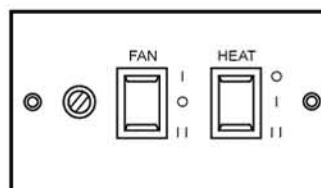

Routine Maintenance

Electrically isolate the air curtain before removing the cover.

After six months the fan should be inspected to ensure there is no build up of dirt or other deposits on the impeller/ motor, electric heater/ water coil. Thereafter it should be checked periodically as experience indicates.

Check security of fixings during routine maintenance.

All Air Curtain fans have sealed for life bearings and no further lubrication is required.