



Belgravia
Fan Convectors



SPC Belgravia Fan Convector

Contents

	Page
1 Belgravia Supreme	3
Supreme dimensions	4
Performance Data	4
Noise Data	4
Electrical data	4
Belgravia Supreme Plus	5
Enhanced coil and lowflow coil option	5
2 Configurations	6
Belgravia Supreme	6
3 Belgravia Classic	7
Classic dimensions	8
Performance data	8
Noise data	8
Electrical data	8
Electric element heating	8
Enhanced coil and lowflow coil option	9
4 Configurations	10
Belgravia Classic	10
5 Enhanced coil options	12
Belgravia Supreme & Classic	12
6 Lowflow coil option	13
7 Active LST	14
8 Belgravia Tilevector	15
Dimensions	16
Performance data	16
Electric element heating	16
Noise data	16
Electrical Data	16
9 Tilevector Plus	17
10 Modulo	18
11 Accessories and options	19

Belgravia Supreme

With the absence of any sharp corners and its ergonomically rounded design, the Belgravia Supreme is the ideal fan convector suited for environments where appearance and safety are paramount.

Through a variety of control options, power ratings and casing configurations, you can adapt the Belgravia Supreme to a wide range of applications.



Dimensions

See page 6 for further configurations

Dimensions				
Model	SPR 40	SPR 60	SPR 90	SPR 150
Length (mm)	800	1000	1300	1600
Height (mm)	735 (775mm)*			
Depth (mm)	235			
Maximum Weight (kg)	31	41	46	52

* Plus unit has increased height

Performance data

Performance at 80/70°C water, 18°C space												
Speed	High				Medium				Low			
Unit size	Airflow (l/s)	Output (kW)	Water flow rate (l/s)	Pressure Drop (kPa)	Airflow (l/s)	Output (kW)	Water flow rate (l/s)	Pressure Drop (kPa)	Airflow (l/s)	Output (kW)	Water flow rate (l/s)	Pressure Drop (kPa)
SPR40	140	5.7	0.14	0.9	112	5.0	0.12	0.7	89	4.3	0.10	0.5
SPR60	236	8.9	0.22	2.3	172	7.4	0.18	1.6	105	5.3	0.13	0.9
SPR90	317	11.7	0.29	4.4	231	9.6	0.24	3.2	120	6.2	0.15	1.5
SPR150	329	16.3	0.40	9.3	289	14.9	0.37	8.0	180	10.5	0.26	4.3

Correction Factors															
Mean Water Temperature (°C)	80				70				60				50		
Water Temperature Drop (°C)	5	10	20	5	10	20	5	10	20	5	10	20	5	10	20
Entering Air Temperature (°C)	-5	1.46	1.40	1.36	1.27	1.24	1.15	1.11	1.05	0.98	0.92	0.86	0.75		
	0	1.38	1.36	1.27	1.20	1.17	1.08	1.02	0.96	0.88	0.83	0.79	0.63		
	5	1.30	1.26	1.19	1.12	1.08	1.00	0.93	0.88	0.79	0.75	0.70	0.52		
	10	1.23	1.18	1.11	1.02	1.00	0.92	0.85	0.81	0.69	0.67	0.61	-		
	15	1.14	1.08	1.02	0.94	0.90	0.82	0.76	0.73	0.58	0.57	0.51	-		
	20	1.05	1.00	0.94	0.87	0.82	0.73	0.67	0.63	0.46	0.49	0.42	-		
25	0.96	0.93	0.86	0.77	0.73	0.63	0.58	0.55	-	-	-	-			

* Factors are approximate. SPC can provide more accurate data if required

Noise data

Noise Data				
Fan setting	High	Medium	Low	
Model	SPR 40	45	38	32
	SPR 60	46	41	35
	SPR 90	43	37	32
	SPR 150	45	44	39

NR levels are based on a room volume that would normally be heated by a single unit of each size shown

Reverberation time of the room is taken to be 0.4 seconds

The listener is assumed to be standing in the middle of the room

The unit is assumed to be wall mounted

Electrical data

230 V / 50 Hz Supply										
Fan setting	High			Medium			Low			
Performance	Airflow (l/s)	EC power draw (W)	EC SFP (W/l/s)	Airflow l/s	EC power draw W	EC SFP W/l/s	Airflow l/s	EC power draw W	EC SFP W/l/s	EC SFP W/l/s
Model	SPR 40	140	27	0.19	112	16	0.14	89	11	0.12
	SPR 60	236	84	0.38	172	53	0.29	105	15	0.14
	SPR 90	317	73	0.23	231	34	0.15	120	18	0.15
	SPR 150	329	80	0.24	289	58	0.20	180	22	0.12

Belgravia Supreme Plus

The Belgravia Supreme Plus range is based on the range of Belgravia Supreme fan convectors and incorporates a fresh air inlet spigot and motorised damper allowing the unit to provide both space heating and ventilation.

See page 6 for styles and dimensions of the unit.

[Contact SPC for more information](#)

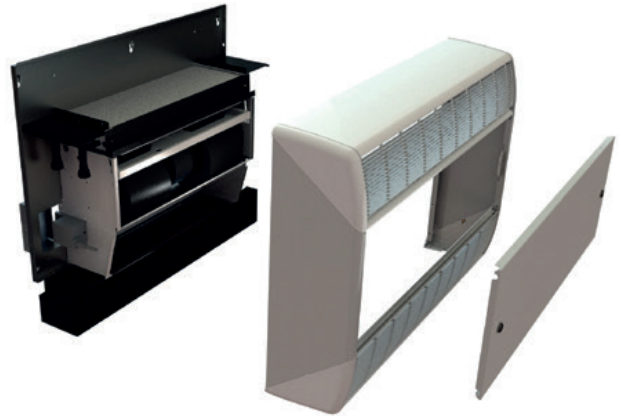

Enhanced coil and lowflow coil option

Our range of SPC Belgravia fan convectors now come with the option of having an enhanced coil, making them suitable for use with low temperature heating systems.

A lowflow coil option is also available for systems with low water flow rates.

For more information on these options, see page 12



Configurations

Belgravia Supreme

Vertical styles

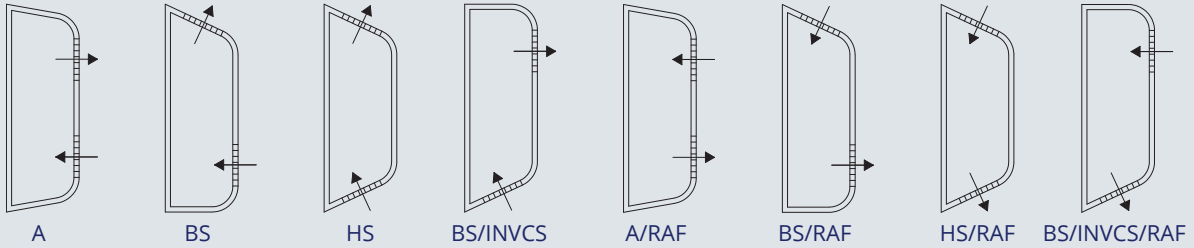

Horizontal styles

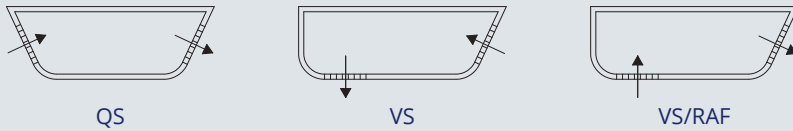

Supreme Plus styles

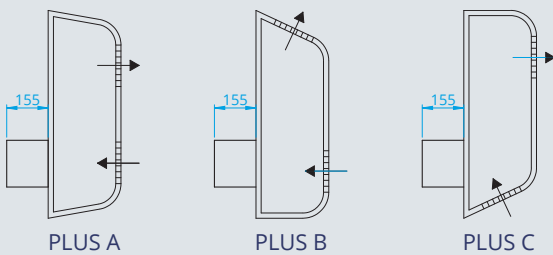

Unit Size	Case Length	Height	Depth	Spigot Width
40	800			650
60	1000	735	235	850
90	1300	(775*)		1150
150	1600			1450

*Plus unit has increased height

Pipe connections $\frac{3}{4}$ " BSP on all models ($\frac{1}{2}$ " on lowflow heat exchangers)

Models not drawn to scale

Belgravia Classic

The Belgravia Classic fan convectors are so named because the traditional design has been used over many decades in thousands of schools nationwide. With clean lines and quiet running, the Belgravia Classic is ideal for sensitive environments.



Dimensions

See page 10 for further configurations

Dimensions				
Model	BEL 40	BEL 60	BEL 90	BEL 150
Case Length (mm)	700	900	1200	1500
Spigot Length (mm)	640	840	1140	1440
Extended case length (mm)	900	1200	1500	-
Extended case spigot length (mm)	840	1140	1440	-
Weight (kg)	32	36	45	57

Performance data

Performance at 80/70°C water, 18°C space												
Speed	High				Medium				Low			
Unit size	Airflow (l/s)	Output (kW)	Water flow rate (l/s)	Pressure Drop (kPa)	Airflow (l/s)	Output (kW)	Water flow rate (l/s)	Pressure Drop (kPa)	Airflow (l/s)	Output (kW)	Water flow rate (l/s)	Pressure Drop (kPa)
BEL40	140	5.7	0.14	0.9	112	5.0	0.12	0.7	89	4.3	0.10	0.5
BEL60	236	8.9	0.22	2.3	172	7.4	0.18	1.6	105	5.3	0.13	0.9
BEL90	317	11.7	0.29	4.4	231	9.6	0.24	3.2	120	6.2	0.15	1.5
BEL150	329	16.3	0.40	9.3	289	14.9	0.37	8.0	180	10.5	0.26	4.3

Correction Factors													
Mean Water Temperature (°C)		80			70			60			50		
Water Temperature Drop (°C)		5	10	20	5	10	20	5	10	20	5	10	20
Entering Air Temperature (°C)	-5	1.46	1.40	1.36	1.27	1.24	1.15	1.11	1.05	0.98	0.92	0.86	0.75
	0	1.38	1.36	1.27	1.20	1.17	1.08	1.02	0.96	0.88	0.83	0.79	0.63
	5	1.30	1.26	1.19	1.12	1.08	1.00	0.93	0.88	0.79	0.75	0.70	0.52
	10	1.23	1.18	1.11	1.02	1.00	0.92	0.85	0.81	0.69	0.67	0.61	-
	15	1.14	1.08	1.02	0.94	0.90	0.82	0.76	0.73	0.58	0.57	0.51	-
	20	1.05	1.00	0.94	0.87	0.82	0.73	0.67	0.63	0.46	0.49	0.42	-
	25	0.96	0.93	0.86	0.77	0.73	0.63	0.58	0.55	-	-	-	-

* Factors are approximate. SPC can provide more accurate data if required

Noise data

Noise Data				
Fan setting	High	Medium	Low	
Model	BEL 40	45	38	32
	BEL 60	46	41	35
	BEL 90	43	37	32
	BEL 150	45	44	39

NR levels are based on a room volume that would normally be heated by a single unit of each size shown

Reverberation time of the room is taken to be 0.4 seconds

The listener is assumed to be standing in the middle of the room

The unit is assumed to be wall mounted

Electrical data

230 V / 50 Hz Supply										
Fan setting	High			Medium			Low			
Performance	Airflow (l/s)	EC power draw (W)	EC SFP (W/l/s)	Airflow (l/s)	EC power draw (W)	EC SFP (W/l/s)	Airflow (l/s)	EC power draw (W)	EC SFP (W/l/s)	
Model	BEL 40	140	27	0.19	112	16	0.14	89	11	0.12
	BEL 60	236	84	0.38	172	53	0.29	105	15	0.14
	BEL 90	317	73	0.23	231	34	0.15	120	18	0.15
	BEL 150	329	80	0.24	289	58	0.20	180	22	0.12

Electric element heating

Electric Unit			
Data	Airflow (l/s)	Output (kW)	Current per phase (A)
Model	BEL 40	112	3.75
	BEL 60	172	6.00
	BEL 90	231	9.00

All units suitable for 400V/50Hz/3Ph supply

Electric units only available as A style

On/off control by switching or remote thermostat or BMS



Enhanced coil and lowflow coil option

Our range of SPC Belgravia fan convectors now come with the option of having an enhanced coil, making them suitable for use with low temperature heating systems.

A lowflow coil option is also available for systems with low water flow rates.

For more information on these options, see page 12



Configurations

Belgravia Classic

Vertical styles

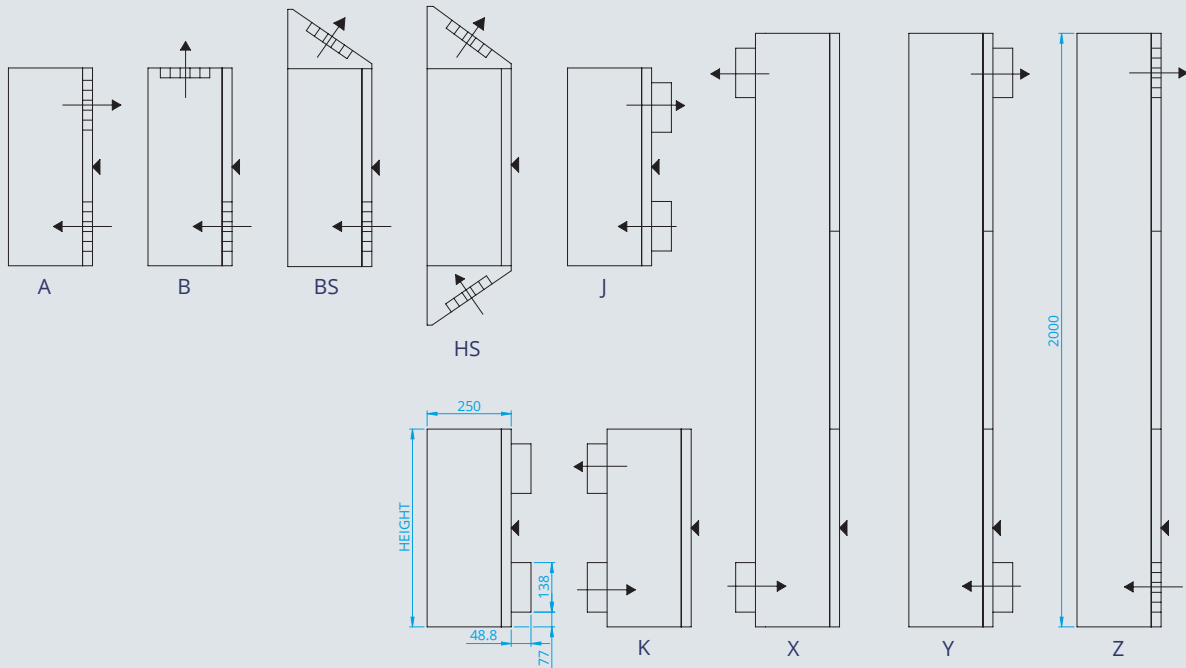

Horizontal styles

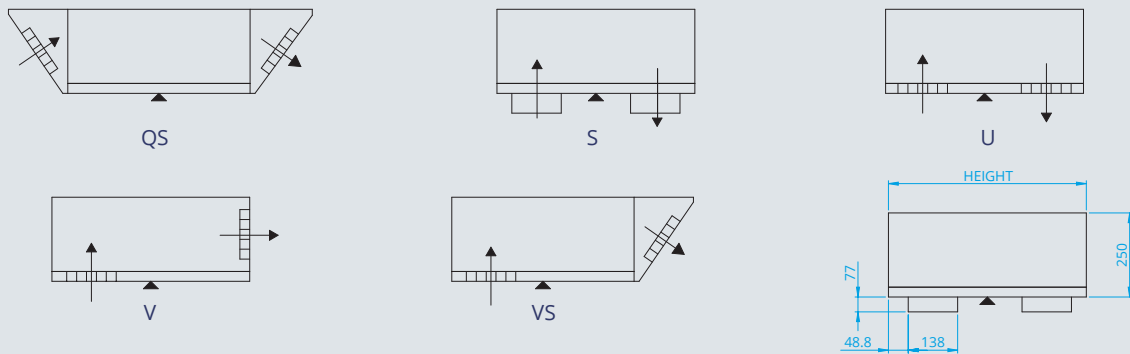

Unit Size	Case Length	Spigot Width
40	700	540
60	900	740
90	1200	1040
150	1500	1340

Height:
 A, B, J, K, S, U, V = 600mm
 BS, VS = 725mm
 HS, QS = 850mm
 X, Y, Z = 2000mm

Most styles available with reversed air flow and/or inverted casing

Style x, y, z standard height at 2000mm. Special height available upon request

Pipe connections 3/4" BSP on all models (1/2" on lowflow heat exchangers)

Models not drawn to scale

Reversed air flow styles

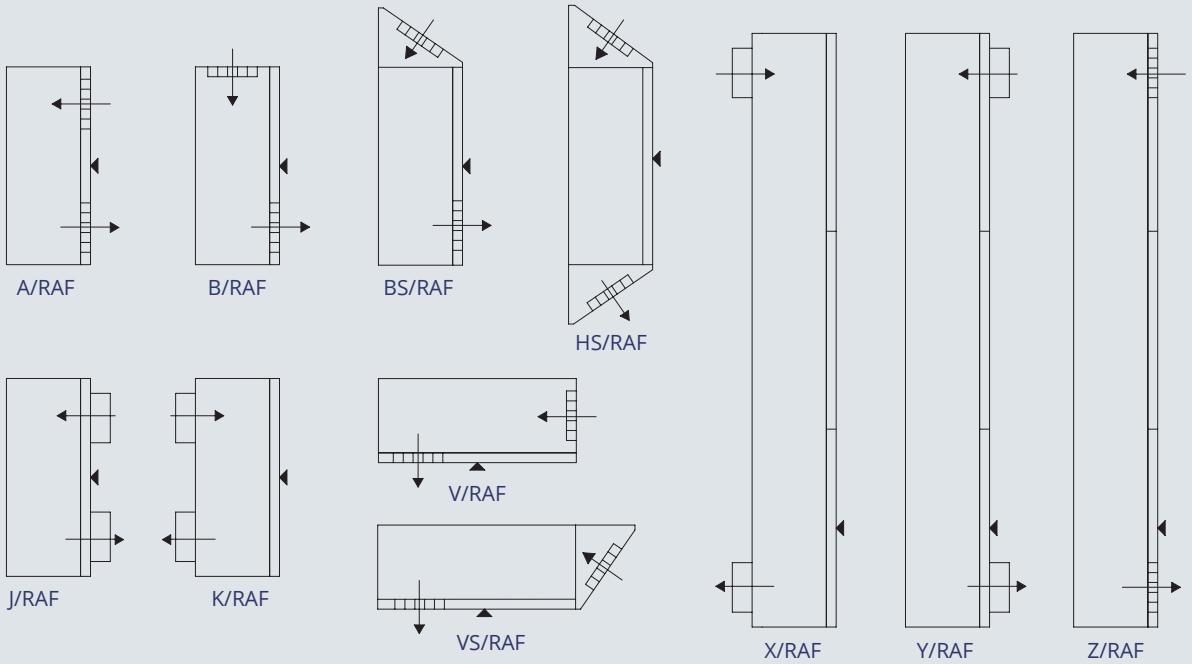

Inverted case styles

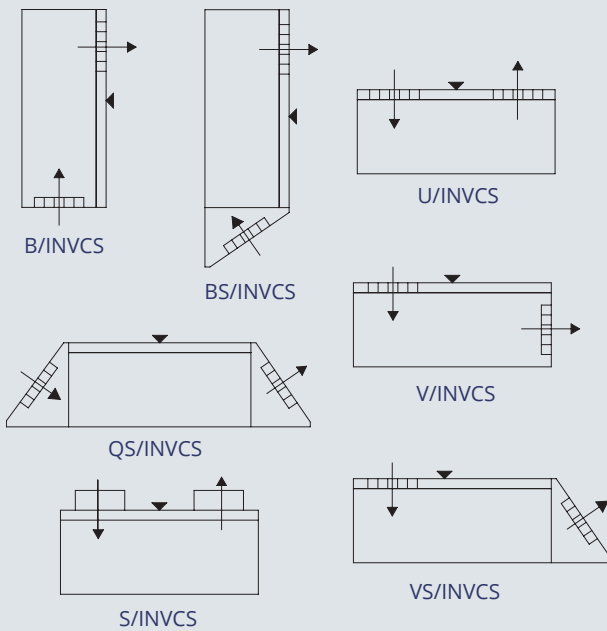

Inverted case + reversed air flow styles

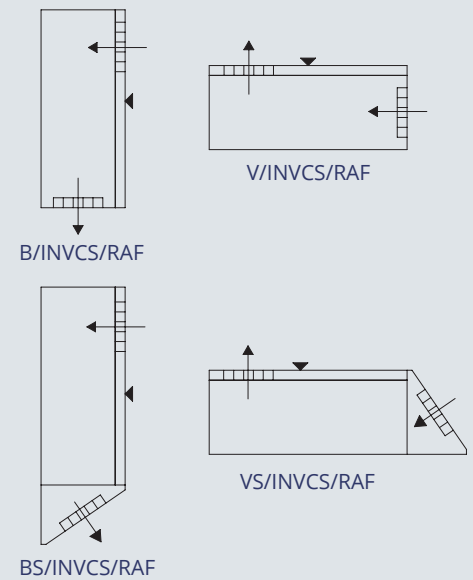

Enhanced coil options

The tables below give details of the outputs obtainable from the range of Belgravia Supreme and Classic units equipped with enhanced low water temperature coils.

If water temperatures are low, as is increasingly the case when heat pumps or condensing boilers

are used, an enhanced coil can be specified.

Enhanced coils have increased surface area to optimise output at low hot water temperatures. If both low water temperatures and lowflow rates are used then the lowflow coil is the better solution.

Belgravia Supreme & Classic

Table 1. Performance at 50/40°C water, 18°C space												
Speed	High				Medium				Low			
Unit size	Airflow (l/s)	Output (kW)	Water flow rate (l/s)	Pressure Drop (kPa)	Airflow (l/s)	Output (kW)	Water flow rate (l/s)	Pressure Drop (kPa)	Airflow (l/s)	Output (kW)	Water flow rate (l/s)	Pressure Drop (kPa)
BEL/SPR40*	126	3.3	0.08	4.2	101	2.8	0.07	3.1	80	2.3	0.06	2.3
BEL/SPR60	212	4.5	0.11	1.2	155	3.5	0.09	0.8	95	2.2	0.06	0.4
BEL/SPR90	285	6.3	0.15	2.6	208	5.1	0.12	1.8	108	3.0	0.07	0.7
BEL/SPR150	296	8.5	0.21	5.1	260	7.7	0.19	4.3	162	5.2	0.13	2.2

Table 2. Performance at 50/35°C water, 18°C space												
Speed	High				Medium				Low			
Unit size	Airflow (l/s)	Output (kW)	Water flow rate (l/s)	Pressure Drop (kPa)	Airflow (l/s)	Output (kW)	Water flow rate (l/s)	Pressure Drop (kPa)	Airflow (l/s)	Output (kW)	Water flow rate (l/s)	Pressure Drop (kPa)
BEL/SPR40*	126	2.4	0.04	1.2	101	1.9	0.03	0.8	80	0.8	0.01	0.1
BEL/SPR60*	212	4.4	0.07	4.0	155	3.5	0.06	2.7	95	2.3	0.04	1.3
BEL/SPR90*	285	6.0	0.10	8.2	208	4.8	0.08	5.7	108	3.0	0.05	2.4
BEL/SPR150	296	7.2	0.12	1.9	260	6.5	0.11	1.6	162	4.3	0.07	0.8

Table 3. Performance at 45/35°C water, 18°C space												
Speed	High				Medium				Low			
Unit size	Airflow (l/s)	Output (kW)	Water flow rate (l/s)	Pressure Drop (kPa)	Airflow (l/s)	Output (kW)	Water flow rate (l/s)	Pressure Drop (kPa)	Airflow (l/s)	Output (kW)	Water flow rate (l/s)	Pressure Drop (kPa)
BEL/SPR40*	126	2.5	0.06	2.7	101	2.1	0.05	2.0	80	1.7	0.04	1.4
BEL/SPR60*	212	4.1	0.10	7.4	155	3.3	0.08	5.1	95	2.3	0.06	2.6
BEL/SPR90	285	4.8	0.12	1.7	208	3.8	0.09	1.1	108	2.1	0.05	0.4
BEL/SPR150	296	6.8	0.17	3.5	260	6.1	0.15	3.0	162	4.1	0.10	1.5

Note. Selections marked * use the 'lowflow' coil with 1/2" pipe connectors, other selections are based on the 'enhanced' coil with 3/4" pipe connectors.

Enhanced or lowflow coils should be considered if water temperatures are below 60°C.



Lowflow coil option

It is increasingly common for fan convectors to be installed in systems which take advantage of low water flow rates to enhance efficiency and provide reduced return water temperature.

SPC manufacture their own coil heat exchangers and are able to offer the Supreme and Classic units with a special 'lowflow' coil to suit the above scenario. This special heat exchanger prevents the rapid fall off of capacity with flow rate.

Performance data

Performance at 60/45°C water, 18°C space												
Speed	High				Medium				Low			
Unit size	Airflow (l/s)	Output (kW)	Water flow rate (l/s)	Pressure Drop (kPa)	Airflow (l/s)	Output (kW)	Water flow rate (l/s)	Pressure Drop (kPa)	Airflow (l/s)	Output (kW)	Water flow rate (l/s)	Pressure Drop (kPa)
BEL/SPR40	126	4.1	0.07	3.0	101	3.5	0.06	2.3	80	2.9	0.05	1.7
BEL/SPR60	212	6.6	0.11	7.8	155	5.3	0.09	5.4	95	3.7	0.06	2.8
BEL/SPR90	285	8.7	0.14	15.3	208	7.0	0.11	10.5	108	4.3	0.07	4.5
BEL/SPR150	296	11.5	0.19	28.9	260	10.4	0.17	24.3	162	7.1	0.12	12.4

Lowflow coils should be considered if the return temperature is 15°C or more less than the flow temperature.



Active LST

SPC have developed a low surface temperature control system for use with its fan convector range. The new controller ensures that surface temperatures remain below the threshold above which there is a risk to vulnerable occupants. According to NHS guidelines this is taken as being equal to 43°C.

Unlike other fan-assisted low surface temperature units 'Active LST' control actively prevents surface temperature increase by monitoring the casing temperature at its hottest point. An independent valve then opens and closes in direct response to the casing temperature.

The closing of the valve reduces water flowrate and casing surface temperature to maintain it at or below the threshold value.

The chart shows temperatures measured on the outlet grille of an SPC fan convector utilising 'Active LST' control. The outlet grille and top panel are the hottest points on the casing.



Measured surface temperatures

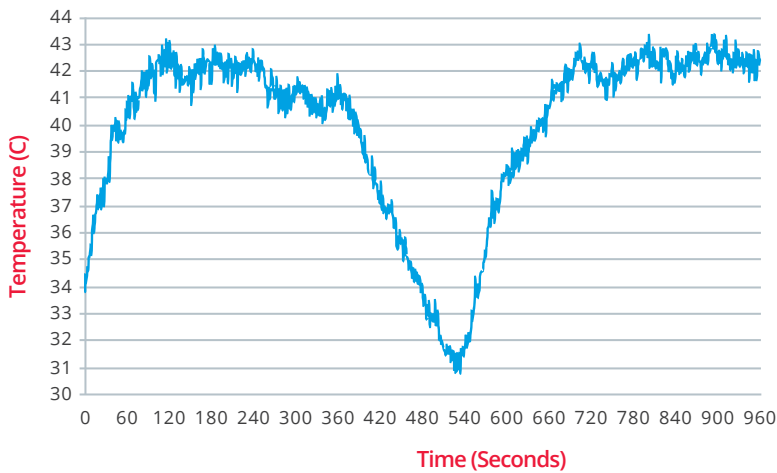

Output Table

Unit size	Nominal length (mm)	Airflow (litres/s)	Capacity (kW)
BEL/SPR40	700	112	3.1
BEL/SPR60	900	172	4.7
BEL/SPR90	1200	231	6.4
BEL/SPR150	1500	289	8.0

Based on water at 80/60°C and 20°C room air.

- Direct sensing of hottest temperature on casing
- Independent control valve modulates to set maximum threshold temperature at 43°C
- Available with a range of capacity control options
- Surface temperature and heating capacity separately controlled
- Ensures compliance with NHS guidelines
- Can be implemented on the full range of available sizes of SPC fan convector
- No additional pipework or wiring required; everything is pre-installed
- Available with rounded ends for enhanced safety
- Available on Classic and Supreme units for A and BS styles'
- LST valve sets terminate in 15mm copper tails

[Contact SPC for further information.](#)

Belgravia Tilevector

Powerful reliable fans are provided to draw in room air and distribute the conditioned air. The combination of air throw and rapid energy transfer brings immediate warmth to those below.

The Belgravia Tilevector range is suitable for installation into both T-Bar suspended ceiling grids (600mm x 600mm) and plasterboard ceilings. They can also be suspended from solid ceilings.



Dimensions

Dimensions		
Model	SOLO	DUO
Length (mm)	595	1195
Width (mm)	595	
Depth (mm)	210	
Maximum Weight (kg)	18	35

Performance data

Performance at 80/70°C water, 18°C space															
Speed	High					Medium					Low				
Unit Size	Airflow (l/s)	Output (kW)	Exit Air Temp (°C)	Pressure Drop (kPa)	Water Flow Rate (l/s)	Airflow (l/s)	Output (kW)	Exit Air Temp (°C)	Pressure Drop (kPa)	Water Flow Rate (l/s)	Airflow (l/s)	Output (kW)	Exit Air Temp (°C)	Pressure Drop (kPa)	Water Flow Rate (l/s)
SOLO	95	3.7	49.9	6	0.09	85	3.4	51.3	5.3	0.08	70	3.1	53.9	4.3	0.07
DUO	190	8.6	55	44.2	0.21	170	8	56.5	39.1	0.19	140	7	59	31.3	0.17

Correction Factors																
Mean Water Temperature (°C)	80				70				60				50			
Water Temperature Drop (°C)	5	10	20		5	10	20		5	10	20		5	10	20	
Entering Air Temperature (°C)	10	1.22	1.19	1.11	1.03	1	0.92	0.86	0.81	0.69	0.67	0.61	-			
	15	1.14	1.11	1.03	0.94	0.92	0.83	0.78	0.72	0.61	0.58	0.53	-			
	20	1.06	1.03	0.94	0.86	0.83	0.75	0.67	0.64	0.5	0.5	0.44	-			
	25	0.97	0.92	0.86	0.78	0.75	0.64	0.58	0.56	0.31	0.42	0.33	-			

* Factors are approximate. SPC can provide more accurate data if required

Electric element heating

Performance Data			
Fan setting	Single speed		
Performance	Air Flow rate (l/s)	Output (kW)	
Model	SOLO	121	3
	DUO	242	6

Noise data

Noise Data				
Fan setting	High	Medium	Low	
Model	SOLO	42	40	36
	DUO	44	42	38
	PLUS	40	38	34

NR levels are based on a room volume that would normally be heated by a single unit of each size shown
Reverberation time of the room is taken to be 0.4 seconds

Electrical data

230 V / 50 Hz Supply										
Fan setting	High			Medium			Low			
Performance	Airflow (l/s)	EC power draw (W)	EC SFP (W/l/s)	Airflow (l/s)	EC power draw (W)	EC SFP (W/l/s)	Airflow (l/s)	EC power draw (W)	EC SFP (W/l/s)	
Model	SOLO	95	18	0.19	85	14	0.16	70	12	0.17
	DUO	190	36	0.19	170	28	0.16	140	24	0.17
	PLUS	152	30	0.2	130	20	0.15	110	15	0.14

Dimensions and weights are given including unit cases and grilles

Coil supplied with 15mm connections on flow and return

Motors are high efficiency EC type

Grilles are hinged, egg-crate style core, all aluminium construction with powder coats or satin-silver finish

Belgravia Tilevector Plus fan convector units for low water temperature applications

The conventional Tilevector fan convector is intended to be fitted in place of a 600mm square tile in a suspended ceiling system. It is designed for optimum operation against traditional hot water temperatures generated by conventional boilers.

The Tilevector Plus has been developed as an alternative unit with enhanced airflow and heat exchanger to optimise operation against the increasingly lower temperature hot water available from heat pumps and condensing boilers.

The tables below give details of the outputs obtainable from the Tilevector Plus unit supplied with various low grade hot water temperatures.

Overall dimensions of the Tilevector Plus unit are 595mm x 595mm x 260mm. This includes the eggcrate grille. Weight is 20Kg. Connections are 15mm copper on flow and return



Table 1. Performance at 50/40°C water, 18°C space

Speed	Low	Medium	High
Output (kW)	2.7	3.2	3.5
Water flow (l/s)	0.06	0.08	0.08
Water PD (kPa)	9.4	13.1	15.4

Table 2. Performance at 45/35°C water, 18°C space

Speed	Low	Medium	High
Output (kW)	2.1	2.6	2.8
Water flow (l/s)	0.05	0.06	0.07
Water PD (kPa)	6.5	8.9	10.6

Table 3. Performance at 50/35°C water, 18°C space

Speed	Low	Medium	High
Output (kW)	2.3	2.8	3.0
Water flow (l/s)	0.04	0.05	0.05
Water PD (kPa)	3.5	4.9	5.8

SPC Modulo v2 is SPC's new proportional controller for fan-assisted heaters

Taking advantage of advances in design of electric motors, SPC Modulo v2, SPC's new proportional controller, is designed especially for incorporation into systems using airside control via 0 to 10V analogue signals. The SPC range of heating units utilise EC/DC fans and in conjunction with the new controller will provide enhanced comfort and energy efficiency.

Simplicity of use is key to the SPC Modulo v2. The thermostat is energised when the touch area

in the top right is pressed and setpoint adjusted by the touch areas in the bottom left and right of the controller – no other settings are required. The controller will then automatically control the rotational speed of the fan depending on the difference between sensed and setpoint temperature.

A transparent coverbox is available with lockable cover if access to the thermostat needs to be restricted.



Key Features

- Energy saving via proportional speed control
- Enhanced comfort via precise thermostatic control
- Easy to use interface via touch area on fascia
- Can be supplied with ventilated, lockable, transparent cover for tamperproof applications.

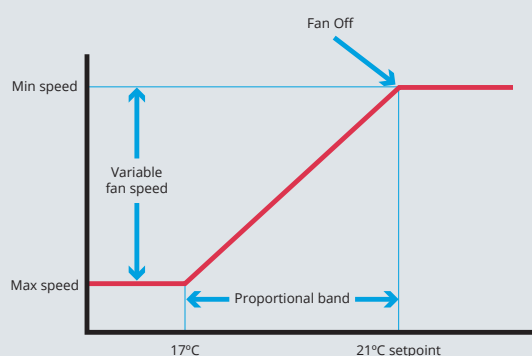

The chart shows how the controller varies the speed of the fan in response to the difference between the actual temperature and the setpoint temperature. Within the proportional band the fan speed is continuously varied to precisely match heat output to the required load.

Accessories and options

Accessories					
	Control	Function	Classic	Supreme	Tilevector
THERMOSTATS	LTC	Low water temperature fan cut-out	✓	✓	✓
	ALTC	Adjustable low water temperature fan cut-out	✓	✓	✓
	T1	In-built on-off control	✓	✓	
	T2	In-built change speed control	✓	✓	
	RT1	Remote mounted on-off control	✓	✓	✓
	RT2	Remote mounted change speed control	✓	✓	✓
	CMT1	Tamper-proof on-off stat	✓	✓	✓
	CMT2	Tamper proof change speed control	✓	✓	✓
	MODULO	Proportional touchscreen controller	✓	✓	✓
SWITCHES	RS1	On-off rocker switch	✓	✓	✓
	RS2	Summer-winter switch	✓	✓	✓
	RS3	Three speed rocker switch	✓	✓	✓
	RS12	Combined on-off / summer-winter rocker switch	✓	✓	✓
	RS13	Combined on-off / change speed rocker switch	✓	✓	✓
	RS23	Combined summer-winter / change speed rocker switch	✓	✓	✓
	RS123	Combined on-off summer-winter & change speed rocker switch	✓	✓	✓
BMS	BMS1	Relay for remote enable/disable signal	✓	✓	✓
	BMS2	On/off and speed control via remote 0-10V signal from BMS	✓	✓	✓
ELECTRICAL CONNECTIONS	FSB	Fuse spur box	✓	✓	✓
	CCB	Customer connection box	✓	✓	✓
AIR SIDE OPTIONS	EAV	Extended air vent	✓		
	RAF	Reverse air flow	✓	✓	
	AF1	Air filter fitted between fan deck and coil	✓		✓
	AF2	Air filter fitted behind the inlet grille	✓		
	AF3	Air filter covering the inlet grille fitted to the motor plate		✓	
	MOD	Manually operated damper	✓		
	POD	Power operated damper	✓		
CASE OPTIONS & ACCESSORIES	SPF	Special paint finish	✓	✓	
	P	Plinth	✓	✓	
	LAP	Lockable access panel	✓	✓	
	TAP	Tamper proof access panel	✓	✓	
	EXTC	Extended casing	✓		
	LGA	Loose grille assembly	✓		
	SWF	Special white finish	✓		
	BOX IF	Metal flush mounting box for single rocker switch	✓	✓	✓
	BOX IS	White plastic surface mounting box for single rocker switches	✓	✓	✓
	BOX 2F	Metal flush mounting box for combined rocker switches	✓	✓	✓
	BOX S2	White plastic surface mounting box for combined rocker switches	✓	✓	✓
	INVC	Inverted casing	✓	✓	
	WM	Wall mounted stiffeners	✓	✓	
LOW SURFACE TEMPERATURE	LST	Low surface temperature unit	✓	✓	
Coil Connector	ISV	Isolating valves for flow and return pipes (Tilevector)			✓

SPC Fan Convector projects

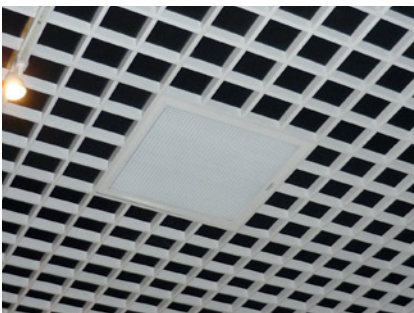

SPC House
Evington Valley Road
Leicester
LE5 5LU

T: 0116 249 0044
E: spc@spc-hvac.co.uk
spc-hvac.co.uk

[SPC Belgravia Fan Convector Brochure 2023 Issue 6](#)

