

# Installation Instructions

# RECESSED MODELS

The ACD and HD Recessed Air Curtains are designed for installation within a false ceiling above door openings. They assist in preventing the ingress of cold exterior air and the loss of conditioned internal air.

**1** Carefully remove packing from air curtain

**2** Remove grill and surround to prevent damage during installation

- slide to unlock grill latching bolts

- lift open hinged grill and remove the four surround retaining screws

- lift away grill and surround and keep in a safe place during installation of the main unit

**3**  Check the overall weight of the unit to ensure safe handling and that the structural ceiling fixings or supports are sufficient

**4** Mount the unit directly to the ceiling or hang using drop rods. For fixing positions refer to model tables and illustrations on Pages 2 and 3

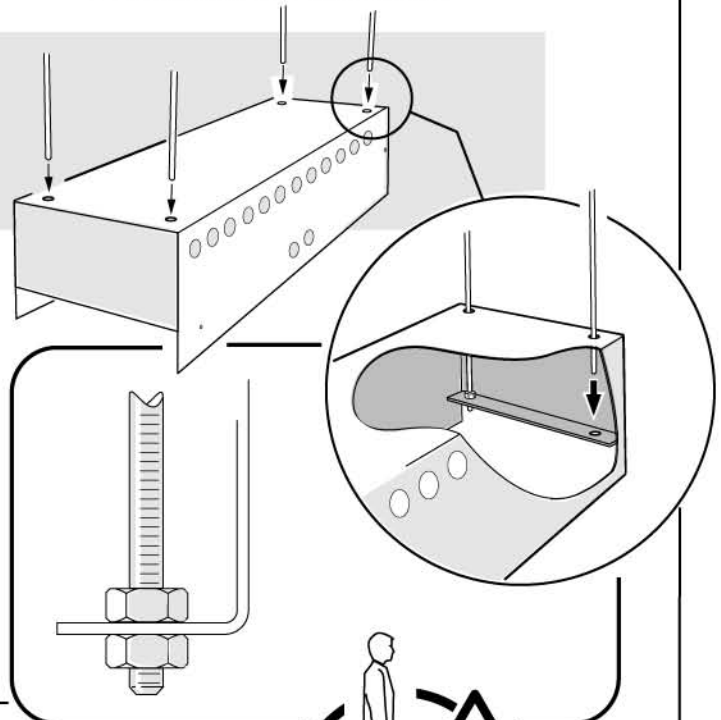

**5** Electrical (and where appropriate plumbing) connections can now be made

Load requirements will vary according to model and whether electrically heated or otherwise. In the case of electrical heaters, these are available in 380/400 3ph only, all other units are 1ph unless specified. Please check relevant circuit diagram when installing. Circuits must be protected with a suitable fuse and the appliance earthed. All electrically heated air curtains are protected with thermal safety cut-outs. these will automatically reset. You must ensure that the electrical cable installed is capable of taking the load indicated on the appropriate wiring diagram or table.

 The units should be wired by a competent electrician and be in accordance with the latest I.E.E. wiring regulations

**6** Refit grill surround and grill. By using the adjustable retaining brackets a close fit can be achieved between the unit and cavity ceiling

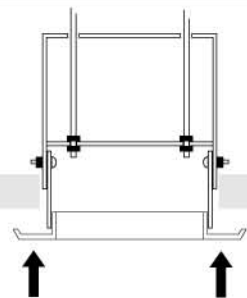
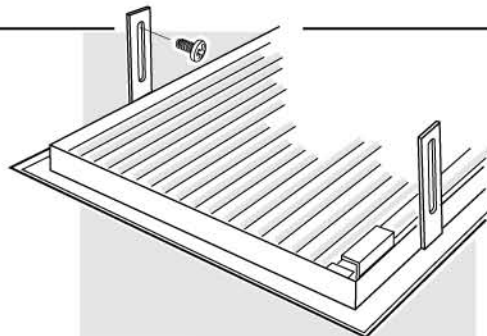

 **Caution**

Dynamically balanced fan scroll. Do not subject to impact during unpacking or installation.

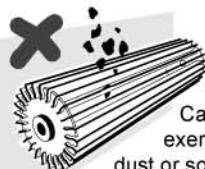

Care should be exercised in preventing dust or solid material from entering the fan scroll.

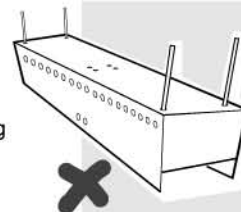

Avoid damage or distortion to the unit, particularly when connecting services.

# Fixing Details

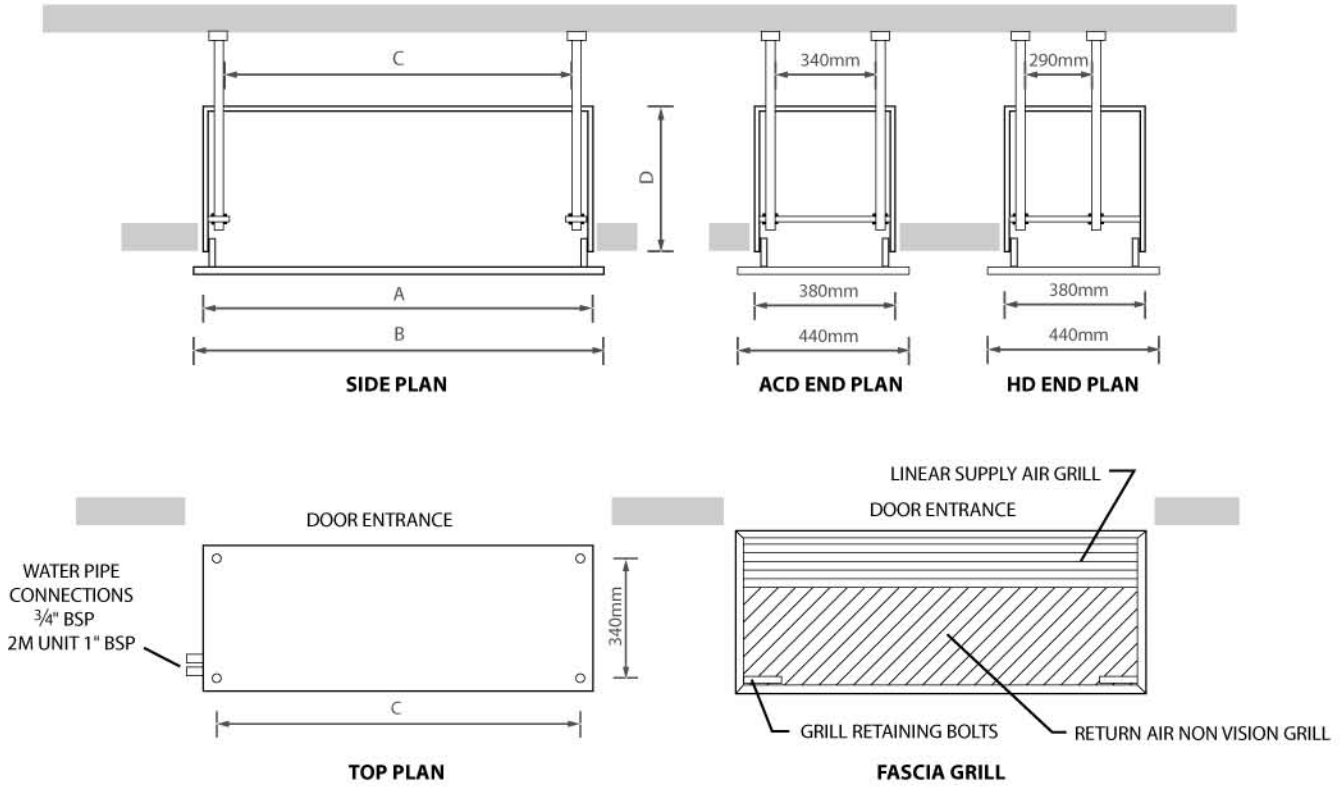

# Wiring Diagrams

## ELECTRIC HEATING UNITS

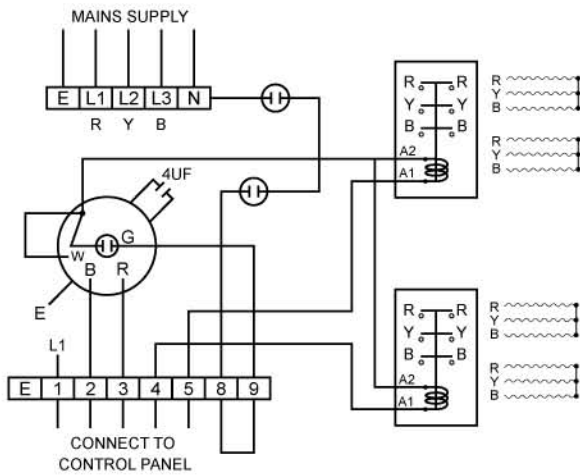

## ELECTRIC CONTROL PANEL

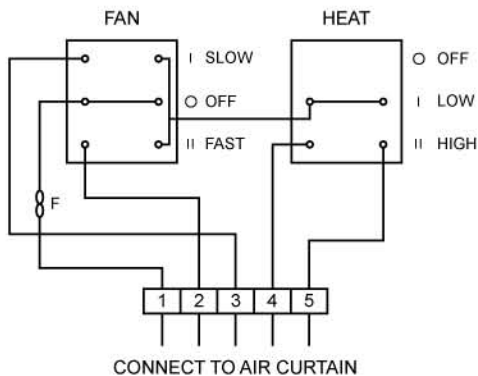

## AMBIENT/WATER UNITS

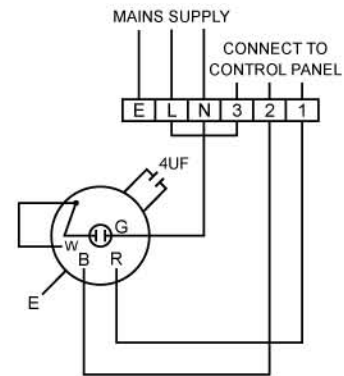

## AMBIENT/WATER UNITS CONTROL PANEL

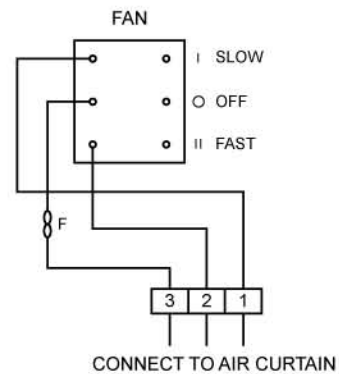

## Technical Details

### RECESSED BACKBOX AND GRILL DIMENSIONS

Model	Unit Dimensions				Weight Kg
	A mm	B mm	C mm	D mm	
ACD 10WR	1140	1200	1115	250	34
ACD 10ER	1140	1200	1115	250	32
HD 10WR	1140	1200	1115	300	36
HD 10ER	1140	1200	1115	300	34
ACD 15WR	1640	1700	1615	250	50
ACD 15ER	1640	1700	1615	250	48
HD 15WR	1640	1700	1615	300	52
HD 15ER	1640	1700	1615	300	50
ACD 20WR	2140	2200	2115	250	68
ACD 20ER	2140	2200	2115	250	64
HD 20WR	2140	2200	2115	300	72
HD 20ER	2140	2200	2115	300	68

Model	Heat output	Max current	Motor power	Voltage	Max air vol m3/h	Max height	Noise level d(B)A
ACD 10AR	-	0.52A	60W	220/1ph	1490	2.7m	55/52
ACD 10WR	8Kw	0.52A	60W	220/1ph	1300	2.7m	54/51
ACD 10ER	7Kw	10A*	60W	380/3ph	1400	2.7m	55/52
ACD 15AR	-	0.52A	60W	220/1ph	2200	2.7m	56/53
ACD 15WR	12Kw	0.52A	60W	220/1ph	2000	2.7m	55/52
ACD 15ER	12Kw	17A*	60W	380/3ph	2100	2.7m	56/53
ACD 20AR	-	0.52A	120W	220/1ph	2980	2.7m	58/55
ACD 20WR	16Kw	0.52A	120W	220/1ph	2600	2.7m	57/54
ACD 20ER	14Kw	20A*	120W	380/3ph	2800	2.7m	58/55

\*per ph Suitable for 230/400/415V supply.

LTHW at 80/60°C

Model	Heat output	Max current	Motor power	Voltage	Max air vol m3/h	Max height	Noise level d(B)A
HD 10AR	-	1.39A	180W	220/1ph	1810	4m	69/66
HD 10WR	11Kw	1.39A	180W	220/1ph	1660	4m	68/65
HD 10ER	12Kw	17A*	180W	380/3ph	1810	4m	69/66
HD 15AR	-	1.39A	180W	220/1ph	2900	4m	71/68
HD 15WR	16Kw	1.39A	180W	220/1ph	2700	4m	70/67
HD 15ER	18Kw	26A*	180W	380/3ph	2640	4m	71/68
HD 20AR	-	2.78A	360W	220/1ph	3620	4m	72/69
HD 20WR	22Kw	2.78A	360W	220/1ph	3320	4m	71/68
HD 20ER	24Kw	35A*	360W	380/3ph	3600	4m	72/69

\*per ph Suitable for 230/400/415V supply.

LTHW at 80/60°C

## Operating Instructions

Air Curtains are supplied with remote control panels as standard. These can either be flush or surface mounted.

Ambient and water heated units have a three position switch giving slow fan speed/ off / fast fan speed.

Electrically heated units are supplied with an extra three position heat switch offering off/ low heat/ high heat.

Each control panel can be used to control single or multiple units.

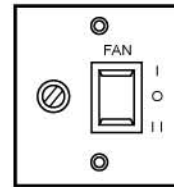
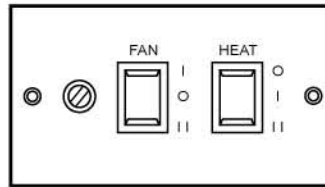

## Routine Maintenance

Electrically isolate the air curtain before removing the cover.

After six months the fan should be inspected to ensure there is no build up of dirt or other deposits on the impeller/ motor, electric heater/ water coil. Thereafter it should be checked periodically as experience indicates.

Check security of fixings during routine maintenance.

All Air Curtain fans have sealed for life bearings and no further lubrication is required.