

BRINGING EFFICIENCY TO HEAT TRANSFER

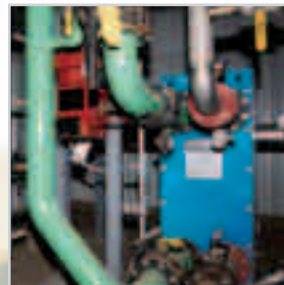

SUPERCHANGER®
PLATE & FRAME HE



Plate & Frame For Maximum Efficiency

Optimum performance is a promise Tranter, Inc., has been fulfilling for many decades with SUPERCHANGER® plate & frame heat exchangers.

Tranter specializes in solving heat transfer problems in a variety of industries—from oil & gas to metals to pulp & paper. Our complete engineering and manufacturing expertise brings you equipment that meets the highest standards of design excellence and quality workmanship.

Got increased production and budget demands? Get efficient, cost-effective solutions with Tranter heat transfer technology.

SUPERCHANGER® Technology Optimizes Ethanol Production Operations

The Tranter heat exchanger program is ideally suited for ethanol processes, with their characteristically high flow rates, high-solids liquids and gas-phase flows. Our units have proven high-uptime performance in difficult ethanol plant applications, such as beer mash cooling and heating. At the same time, their superior heat transfer efficiency reduces fuel costs. SUPERCHANGER heat exchangers are applicable to new plant designs or existing plant retrofits as part of a key strategy to reduce operating costs.

The information contained in this brochure is not intended to be used for engineering purposes and is for reference only. Updates in design or manufacturing methods may affect some of the data. Please consult the factory for more information.



Efficient Heat Transfer For Every Industry

The SUPERCHANGER heat exchanger is designed to provide maximum efficiency in transferring heat from one liquid to another or from steam to liquid.

It consists of a series of gasketed, embossed metal plates arranged alternately and bolted together between end frames to form channels through which hot and cold media flow. The hot fluid flows on one side of the plate while the cold fluid flows on the other, with the plate itself providing the most effective means to transfer heat from one fluid to the other. Gaskets on the plates seal the channels and provide flow direction.

As liquids flow counter-currently through the channels between the plates, the cold liquid becomes warmer and the hot liquid cooler. Most units are designed for a one-pass/one-pass flow arrangement, resulting in all nozzles being installed on the stationary end frame, which facilitates simpler piping arrangements and easier disassembly.

Due to its high efficiency, the SUPERCHANGER unit can handle temperature approaches of less than 2°F (1°C). It also offers “U” values in excess of 1,500 Btu/hr ft² °F, which is significantly greater than other exchangers, due to the unique turbulence created by its corrugated plates, which eliminates stagnant areas in liquid flow and promotes maximum heat transfer. This translates to a less expensive and more compact heat exchanger.

The unit’s velocity profile and induced turbulence causes dirty product deposits to be continually removed from the heat transfer surface during operation, thereby reducing fouling.

Effective use of the plate’s turbulence can be made with in-place cleaning, which allows backflushing water or pumping cleaning solutions into the unit without disassembling. Units can also be taken apart for cleaning the plate surfaces. Plates can be electropolished to make cleaning easier, either manually or in-place.

Applications

Energy

- Solar collector fluid isolation
- Heat recovery in co-generation facilities
- Turbine cooling in power plants
- Geothermal water isolation
- Isolation and “free cooling” in HVAC
- Heat recovery from boiler blowdown
- District chilled water coolers

Pulp & Paper

- Heat recovery from de-inking effluent
- Jacket water cooling in black liquor recovery process
- Heating white water in paper mills
- Cooling bleach solutions

Integrated Systems

- Welder water coolers
- Cooling machine oil
- Cooling grinder coolant
- Cooling electronic equipment
- Hydraulic oil coolers

Metals

- Heating phosphatizing solutions
- Acid coolers
- Cooling ammonia liquor at coke plants
- Cooling anodizing solutions
- Heating of electrolyte solution in copper mills
- Cooling quench oil
- Heating and cooling plating solutions

Chemicals

- Waste heat recovery from condenser water
- Heating or cooling jacket fluid for chemical reactors
- Heating and cooling chemical solutions

Maritime

- Lube oil cooling
- Cooling engine jacket water
- Heating ship service water

Food & Beverage

- Heating wash water
- Heating and cooling sugar solutions
- Ethanol distillation

Oil & Gas

- Heat recovery from lean to rich amine solutions

Miscellaneous Manufacturing

- Preheat make-up water in photo processing
- Paint coolers
- Heating and cooling kaolin slurries

How SUPERCHANGER PHEs Outperform Shell & Tube Units

SUPERCHANGER heat exchangers transfer heat more efficiently than shell & tube units in most applications, due in large measure to the turbulent flow created by the corrugated patterns of their plates.

They can pack greater than 22,000 ft² (2,044 m²) of super-efficient heat transfer surface in a single unit with flow rates up to 25,400 gpm (5,768 m³/hr).

They use only 10-50% of the space required by shell & tube units and are much lighter in weight.

And, they cost less.



SUPERCHANGER Plate & Frame

- “U” values several times greater than shell & tube
- Can be designed for less than 2°F (1°C) temperature approach
- Opens for access within its own footprint
- Easy disassembly—simply loosen bolts and roll movable frame back to the support column to remove plates
- Low fouling due to corrugations and inherent turbulence
- Intermix between fluids virtually impossible due to gasket design
- Practically no heat loss—no insulation required

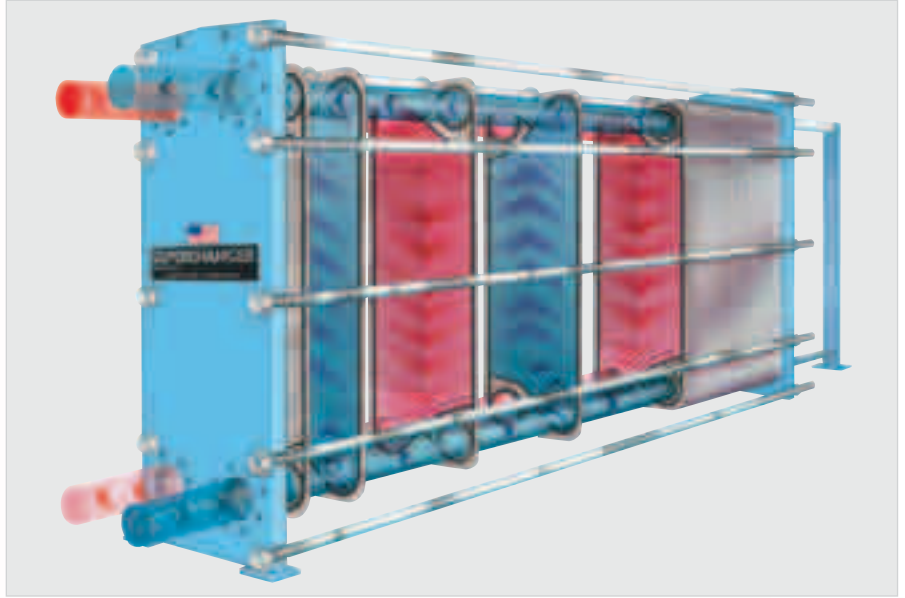

Demonstrated here is the SUPERCHANGER® heat exchanger efficiently handling heat transfer flow.



Shell & Tube

- Low efficiency
- Typically designed for greater than a 5°F to 10°F temperature approach
- Requires twice its length to pull tube bundle
- Complex disassembly—tube bundle must be pulled
- Three to 10 times greater fouling due to circular cross-section and channeling
- Fluids can intermix, both at welds and at tube sheet
- Great amount of heat loss—insulation required



World-Class Manufacturing, Superior Testing And Servicing

ISO 9001 certification

Tranter is ISO certified, adhering to the highest standards in designing, manufacturing and testing SUPERCHANGER plate & frame heat exchangers.

SUPERCHANGER heat exchangers are computer designed and analyzed by technical specialists, who generate a complete proposal providing optimum designs and alternatives. Quotes are prepared on a timely basis with all technical information required for evaluation.

SUPERCHANGER unit components are manufactured by state-of-the-art production technology and assembled by the most knowledgeable, experienced craftsmen using the best equipment and fabrication techniques available.

Tranter can custom design a unit with the specific number, size, material and configuration of plates to meet your exact needs. If your needs change, the unit can be easily modified by simply adding or removing plates.

Each unit is thoroughly tested

After assembly, each SUPERCHANGER unit is hydrostatically tested, both single and double sides, at the required test pressures.

A number of additional tests, including process simulation and fatigue tests, can be performed to guarantee a unit fulfills your strict operational requirements.



GTAW and GMAW welding processes are utilized on nozzles and end frame reinforcing bars, respectively.



Many high precision tools are manufactured in-house.



Draw depths of plate chevrons are meticulously monitored.



A modern, fully equipped lab offers a wide range of tests.



Tranter plates are formed using a one-bit process.

Precise Plate Selection

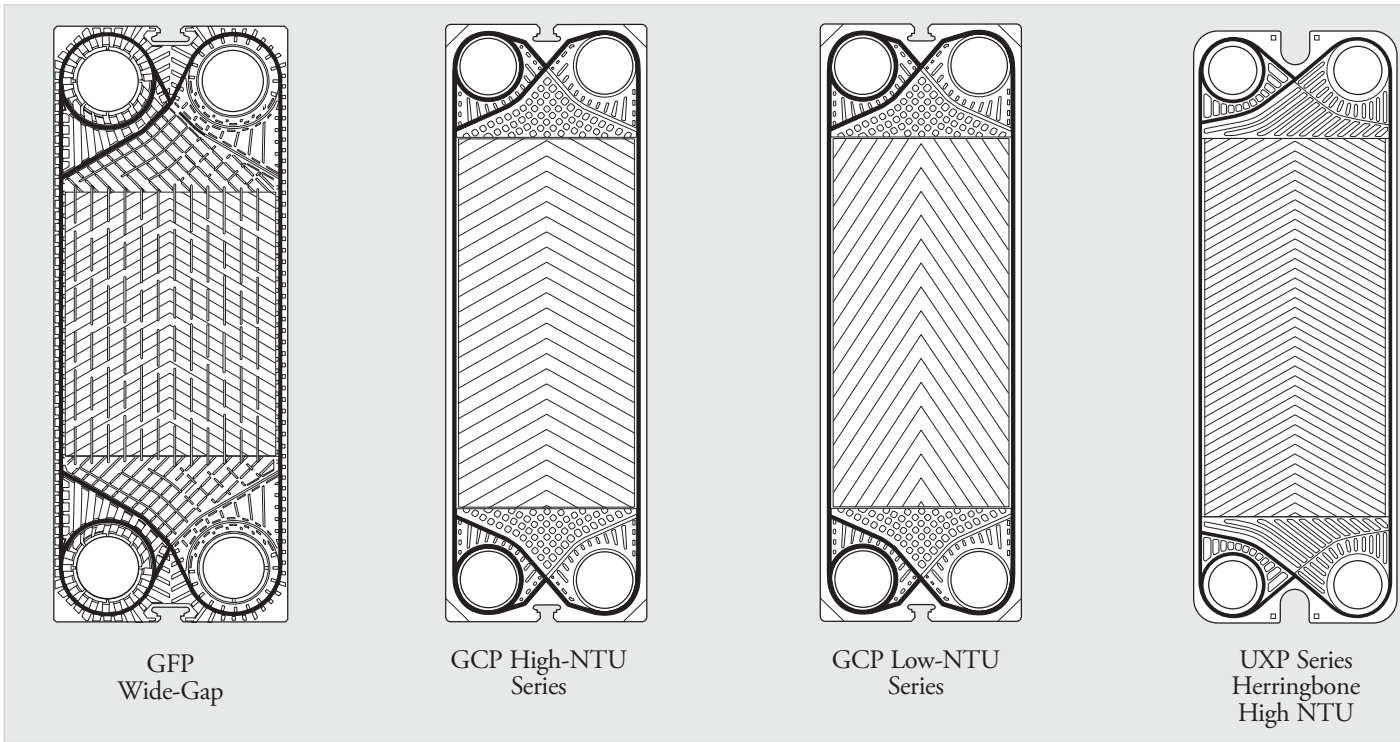

GFP Wide-Gap

Wide-Gap plates are most effective in applications that involve viscous fluids or solids and slurries. These normally cause extensive clogging and downtime for cleaning with standard plate & frame or shell & tube heat exchangers. Our plates have a draw depth two to five times greater than conventional plates, permitting unrestricted passage of coarse particles and fibers.

Plates can be arranged in a wide/narrow configuration when only one fluid with large particulates requires a wide gap or placed in a medium/medium position when both fluids need the additional flow area. Both configurations are accomplished with a single plate geometry.

Wide-Gap plates are excellent for steam applications as well.

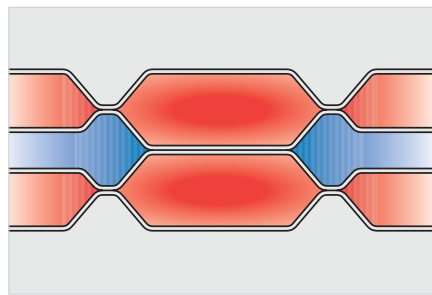

Wide/Narrow

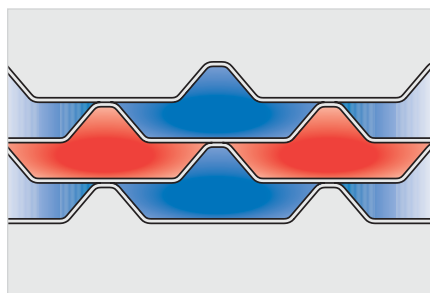

Medium/Medium

GCP Series

The latest GCP high-and low-NTU plates feature an innovative redesign of the flow distribution area. They are very suitable for both steam and viscous fluid applications that require high heat-transfer rates at low pressure drops.

UXP Series

UXP Series plates have corrugations in a traditional herringbone or chevron pattern, offering a variety of thermal lengths. They are used in a multitude of applications and are generally more efficient with relatively clean solutions due to greater induced turbulence within the flow stream.

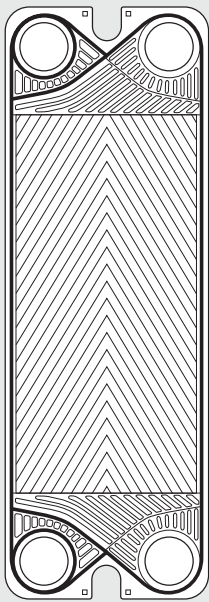

UXP Series
Herringbone
Low NTU

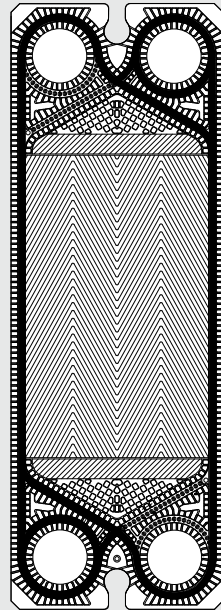

GL Series

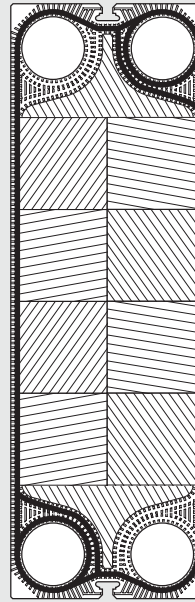

GXD Series
High NTU

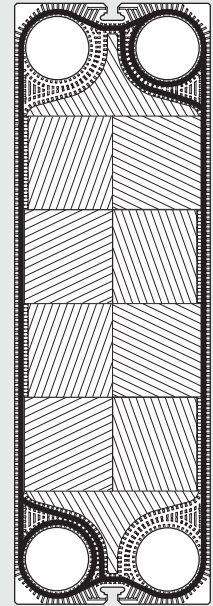

GXD Series
Low NTU

Illustrations shown here are not drawn to scale. NTU = thermal length.

GL Series

GL Series plates offer broad versatility and responsiveness for a wide range of applications. These herringbone-style plates have a large theta span, enabling finely tuned pressure drop and heat transfer rate. They have proven to provide outstanding performance in condensing applications.

Mixed High-And Low-NTU

In many applications, better heat transfer performance can be achieved by units with mixed high-and low-NTU plates having varying angles. In these duties, fewer plates are required because thermal and hydraulic requirements can be almost exactly matched.

GXD Series

Especially when flows are unbalanced and the allowable pressure drops are reasonably close, Tranter utilizes its GXD Series plate designs. Better accommodation of unequal flow rates, which optimizes pressure drop and heat transfer rates for both fluids, furnishes the best overall system efficiency and results in a lower cost unit.

GXD plate technology utilizes two asymmetrical plate patterns to create six different flow channel configurations. And, with more than 100 available plate combinations, we can better fit your specific heat transfer needs.



GXD Series with asymmetrical plate patterns.



GFP Wide-Gap Plates Defeat Clogging And Downtime

A SUPERCHANGER heat exchanger utilizing Wide-Gap plates economically recovers heat from hard-to-handle waste streams in a variety of industries, including pulp & paper, sugar processing, alcohol production, grain processing, chemicals, textiles and ethanol distilling.

The plate design is also excellent for low-pressure steam since the wide gap will more readily accommodate the high volumetric flows typical of low-pressure steam applications.

Plates are available in five models—designated GFP-205, GFP-187, GFP-145, GFP-097 and GFP-057, with nozzle diameters ranging from 8 in. to 12 in. (200 mm to 300 mm).

Plate materials

Standard materials are 304SS and 316SS. Custom requirements for Hastelloy® C-276, 254SMO or other alloys, which can be cold formed, can also be accommodated.

Standard plate thickness is 0.032 in. (0.8 mm), with a 0.039 in. (1.0 mm) option available.

Gasket materials

NBR or EPDM gaskets are offered as standard. Maximum temperature with NBR is 250°F (120°C); EPDM is 320°F (160°C).



GFP-205, GFP-187, GFP-145, GFP-097 and GFP-057.

Wide-Gap Plate Specifications

| Model No. | Design Pressure, psig (barg) | Nozzle Size, in. (mm) |
|-----------|------------------------------|-----------------------|
| GFP-057 | 150 (10) | 8 (200) |
| GFP-097 | 150 (10) | 8 (200) |
| GFP-145 | 150 (10) | 8 (200) |
| GFP-187 | 150 (10) | 8 (200) |
| GFP-205 | 150 (10) | 12 (300) |

Maximum Particle Size

| Gap | Maximum Particle, in. (mm) |
|--------|----------------------------|
| Narrow | 0.14 (3.5) |
| Medium | 0.28 (7.1) |
| Wide | 0.40 (10.1) |

GXD Plate Technology Offers Unparalleled Plate Section

Tranter’s GXD plate technology provides SUPERCHANGER PHEs with features that now surpass conventional design barriers. Offering the broadest selection of plate patterns and sizes in the heat exchanger market, SUPERCHANGER units provide more plate combinations for maximum system efficiency. This means more options to meet all of your HVAC heat transfer requirements:

- Lower operating costs realized through maximum thermal efficiency, reduced fouling and less frequent cleaning
- Closer temperature approaches
- Reduced cooling media volume, since flow characteristics for both fluids can be optimized
- Better accommodation of unequal flow rates that optimize pressure drop and heat transfer rates for both fluids, furnishing the best overall system efficiency

The GXD plate technology utilizes two plate patterns to achieve six different flow channel configurations. Why is this technology better? Having the option to create six different configurations with just two plate styles allows us to more closely optimize the pressure drop to the heat transfer requirement—a better match to your needs as you go beyond conventional design to stay ahead of your competition.

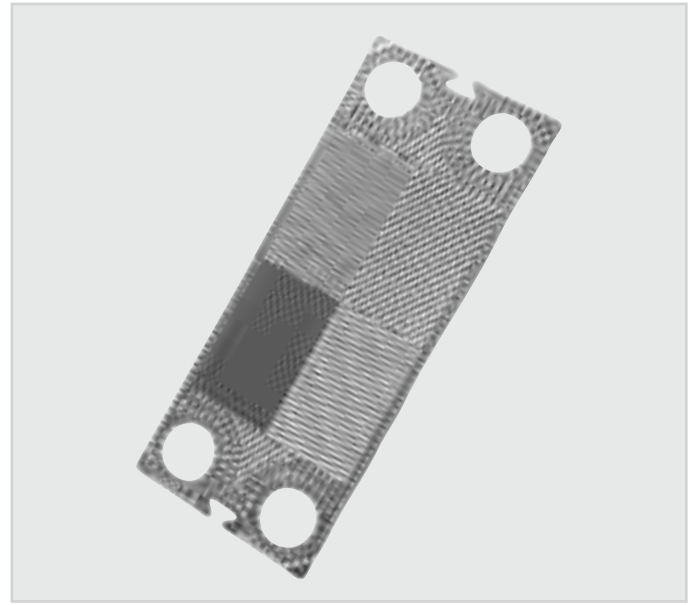

GXD Series High-NTU Plate

Typical GXD Applications

Cooling

- Cooling tower water circuit isolation
- “Free cooling” during moderate temperatures
- Isolation and “free cooling” combination
- Isolation of river, lake, waste or seawater coolants
- Static head isolation in tall buildings
- Thermal storage— isolation of storage tank
- Water source heat pump precooler with isolation

Heating And Heat Recovery

- Waste heat recovery from condenser water
- Water source heat pump isolation
- Waste heat recovery from condensate or boiler blowdown
- Solar collector fluid isolation
- Waste heat recovery from overheated areas
- Geothermal heating isolation
- District or zone heating building isolation
- Heating water/glycol fluids for space heating

Two Plates Achieve Six Combinations

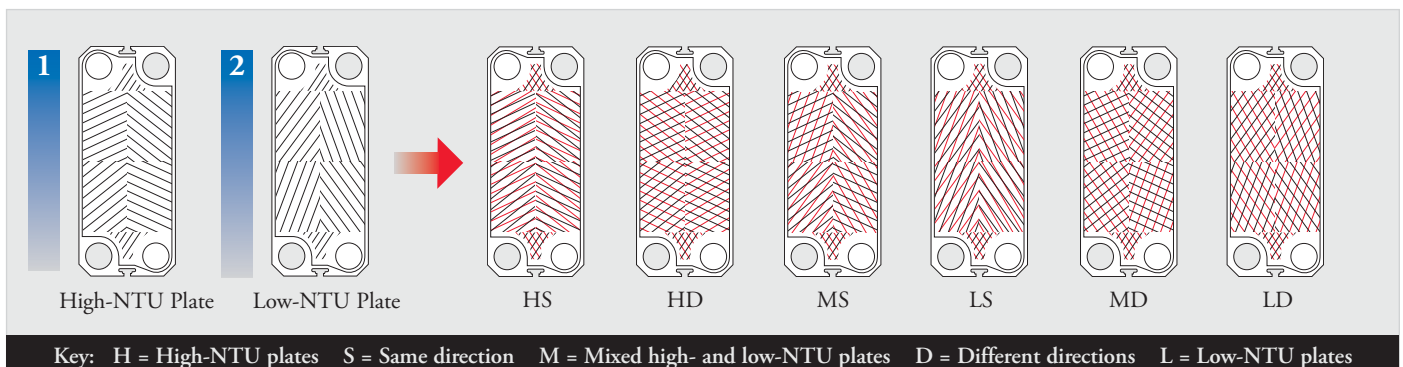



GCP Series Plates Utilize Innovative Flow Design

Applications where low pressure drop is required or unit sizing is limited by pressure drop are a perfect match for the GCP Series plate.

Tranter's GCP Series plates—GCP-026, GCP-051 and GCP-060—are designed with a conventional herringbone pattern, with the gasket groove in the bottom plane. The plate design is similar to the UXP Series in that flow direction is parallel (or vertical) in contrast to the GXD Series, which features diagonal flow across the plate. Due to the deeper draw depth and the “chocolate” pattern in the flow distribution area, the GCP Series plates yield a significantly lower pressure drop than the corresponding GXD Series plates. Both high- and low-NTU versions are available in all three GCP Series plates. This allows the flexibility to satisfy a wide range of applications.

Applications suitable for the GCP Series plates are those where low pressure drop is critical or where unit sizing tends to be limited by pressure drop (low NTU).

Typical examples are:

- Steam-to-liquid
- District heating
- Engine jacket water cooler
- Heating/cooling viscous materials

Tranter has already provided many GCP Series units in the automotive (phosphate, paint, etc.) and basic metals industries.

Standard plate materials are 304SS, 316SS and titanium, but requirements for Hastelloy C-276, 254SMO or other cold-formed alloys can be accommodated. Standard gasket materials are NBR, EPDM and Fluoroelastomer.

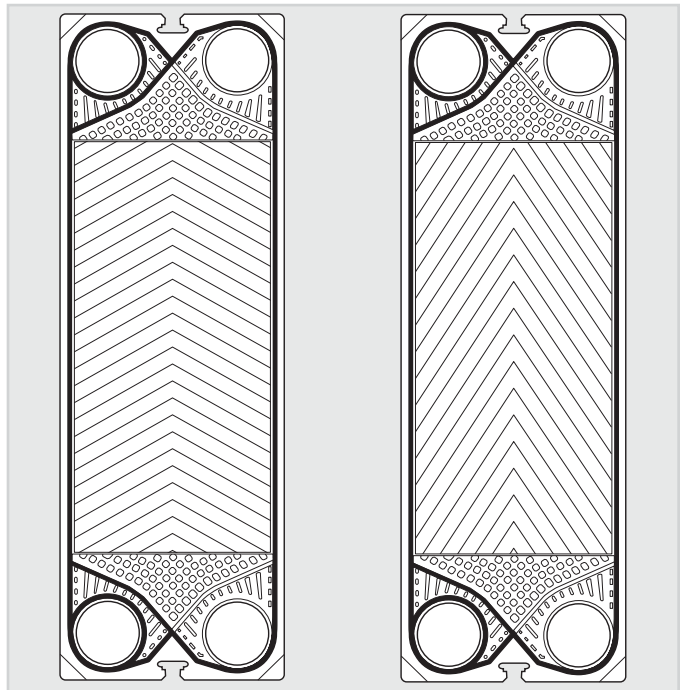

GCP High-NTU (left) and GCP Low-NTU Series plates.



A Closer Look At GD Series Double-Wall Plates

The double-wall plate heat exchanger is intended for use where the two fluids on each side of the plates should not mix—due to possible contamination or an undesirable reaction.

If a leak through one of the plates or around one of the gaskets should occur, the fluid is vented to the outside of the heat exchanger before any intermixing can occur. The leak is immediately evident even before disassembly of the heat exchanger.

Some popular industries and applications that utilize GD Series plates include:

- Pharmaceutical industry
- Food & beverage industry
- District heating
- Cooling of transformer oil
- De-ionized water

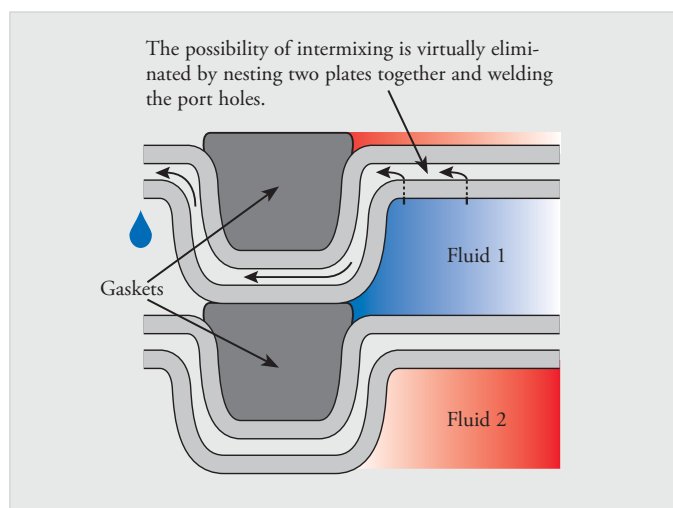

The nested plates are gasketed and assembled to form the plate pack.

Tranter GD Series double-wall plate packs significantly reduce the risk of contamination by channel intermixing in critical externally heated vessels and reactors in pharmaceutical, biopharmaceutical, food & beverage and various CPI applications.





Advanced Gasket/Bleed Port Design

With Tranter's exclusive gasket/bleed port design, fluids will not intermix (other than a through-plate failure) when the plates are properly gasketed and the unit is assembled in accordance with prescribed instructions and design specifications. Liquid flowing on the surface of each plate flows on the inside of the boundary gasket. Should one of the liquids leak beyond a boundary gasket, it will flow to the outside of the unit through the bleed ports, preventing intermixing.

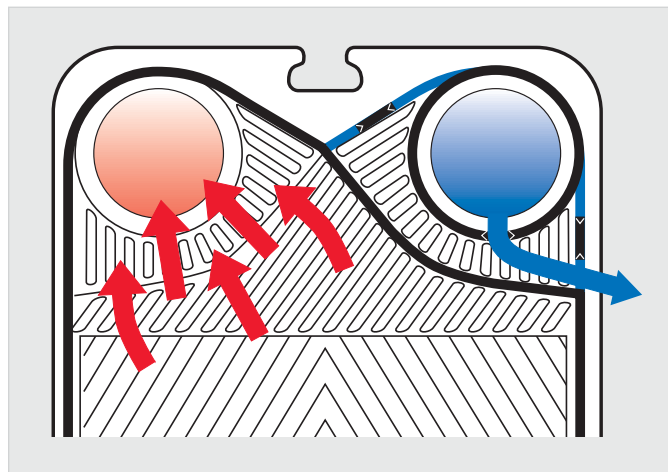

Bleed ports convey boundary gasket leaks to the exterior, preventing intermixing.

A Wide Range Of Choices

The broad range of materials currently available for SUPERCHANGER plate & frame heat exchangers provides a diverse selection for meeting an exceptionally wide variety of individual needs.

Plate choices

SUPERCHANGER plates are pressed in Wichita Falls, Texas, and produced in virtually any metal that can be cold-formed, including: stainless steels (304, 316, 317, etc.); titanium; Monel®; nickel; alloys 825, 20Cb-3, B-2 and C-276; and a variety of other materials.

Plates are available in sizes ranging from 0.64 ft² (0.06 m²) to 36.27 ft² (3.37 m²) and in thicknesses from 0.016 in. (0.4 mm) to 0.039 in. (1.0 mm).

Trial units

SUPERCHANGER units are available on a 90-day, no-charge basis for customer in-plant testing and evaluation. Contact your Tranter representative for information on the SUPERCHANGER trial unit policy.



Plates are pressed in virtually any cold-formable metal and furnished with the right gasket materials to match your process conditions.

Gasket choices

SUPERCHANGER plate gaskets are specially molded elastomers to assure superior performance.

Numerous gasket materials—NBR, EPDM, Viton, Neoprene, Butyl, Hypalon, Teflon-encapsulated NBR and others—are available to match your process conditions, to maximum operating temperatures of 366°F (185.5°C).

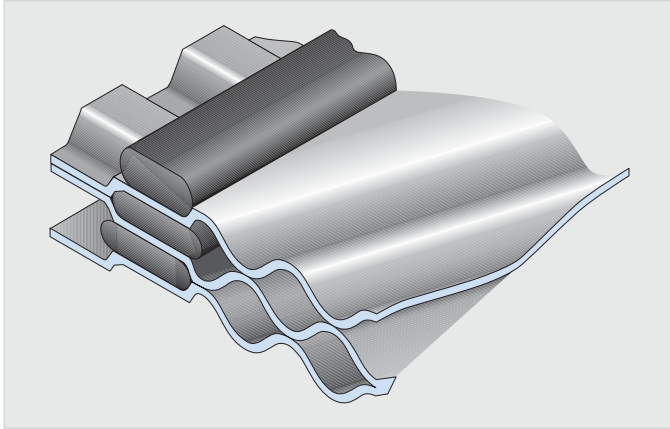

Gaskets on GXD Series plates are located in the neutral axis.

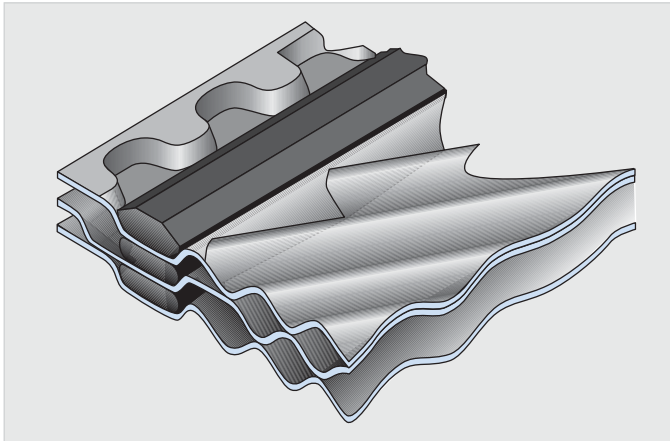

Gaskets on all other plates are located in tapered grooves.

Consider the Tranter Clip-On glueless gasket system wherever regular cleaning is necessary or aggressive fluids shorten gasket life. The unique design allows easy and fast clip-on installation for sure sealing and simple removal.

The Clip-On is available in NBR and EPDM, both industrial and FDA ratings. These precision gaskets are molded under rigorous manufacturing controls and are peroxide-cured for long life and excellent compression set resistance. Typical ratings are 338°F (170°C) at low pressures and 357 psig (25 barg) at moderate temperatures, depending on application conditions.

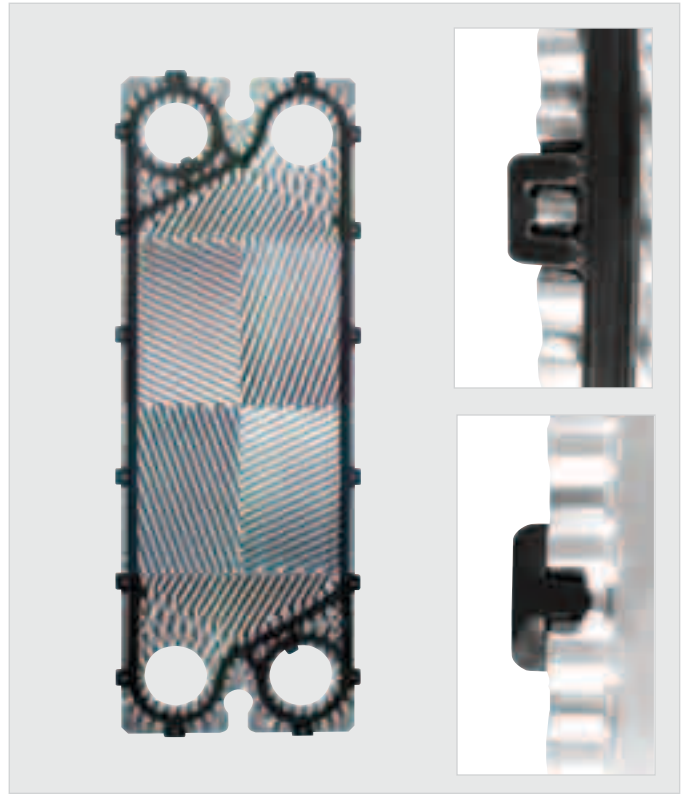

Clip-On gaskets seat and lock-in without tools for trouble-free plate pack assembly and installation.

Fully glued or SPOTGLUED® gaskets, which require less downtime to install, remove or clean, can be specified for most units.



SPOTGLUED Gaskets



Frame choices

Tranter offers both solid and reinforced end frames, which can be ASME Code stamped up to a design pressure of 400 psig (27.56 barg). Standard frames are painted 0.025 mm to 0.076 mm (1 mil to 3 mil) DFT carbon steel, with zinc plated tightening bolts and optional aluminum shrouds. Compact versions with no support column are available on some units. Stainless steel tightening bolts and connecting frames are optional.

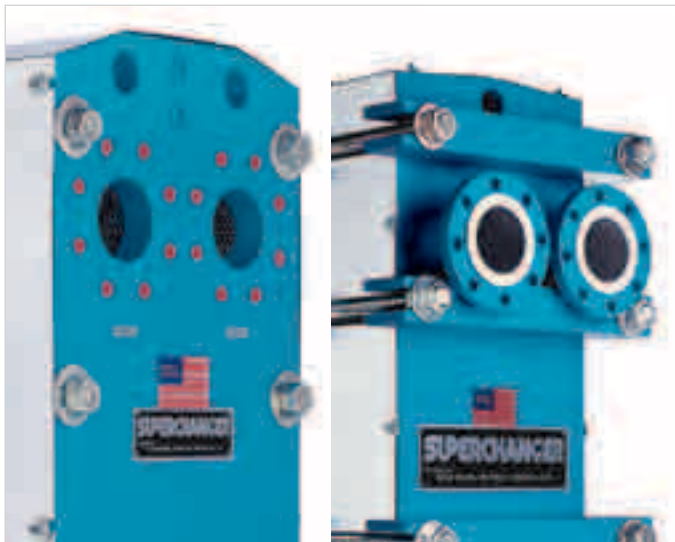

Frame choices include studded or flanged ports and solid or reinforced frames.

Nozzle choices

Tranter offers ASA loose flange type nozzles as standard on reinforced end frames and studded port connections as standard on solid end frames. In addition, threaded pipe, sanitary and Victaulic connections are available.

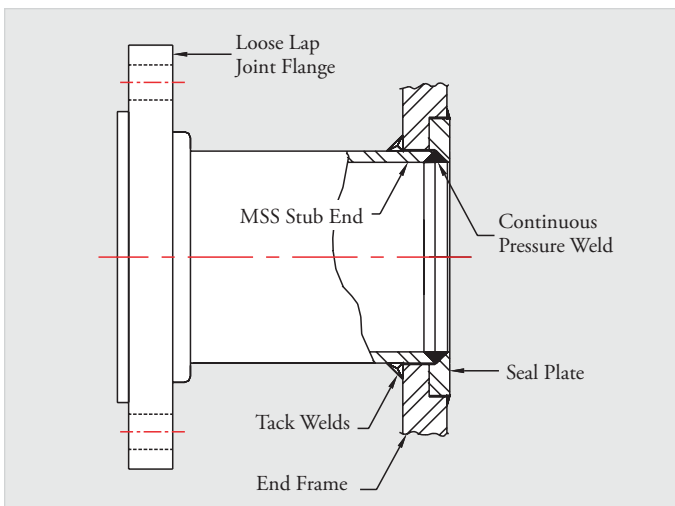

Flanged Nozzle Cross Section

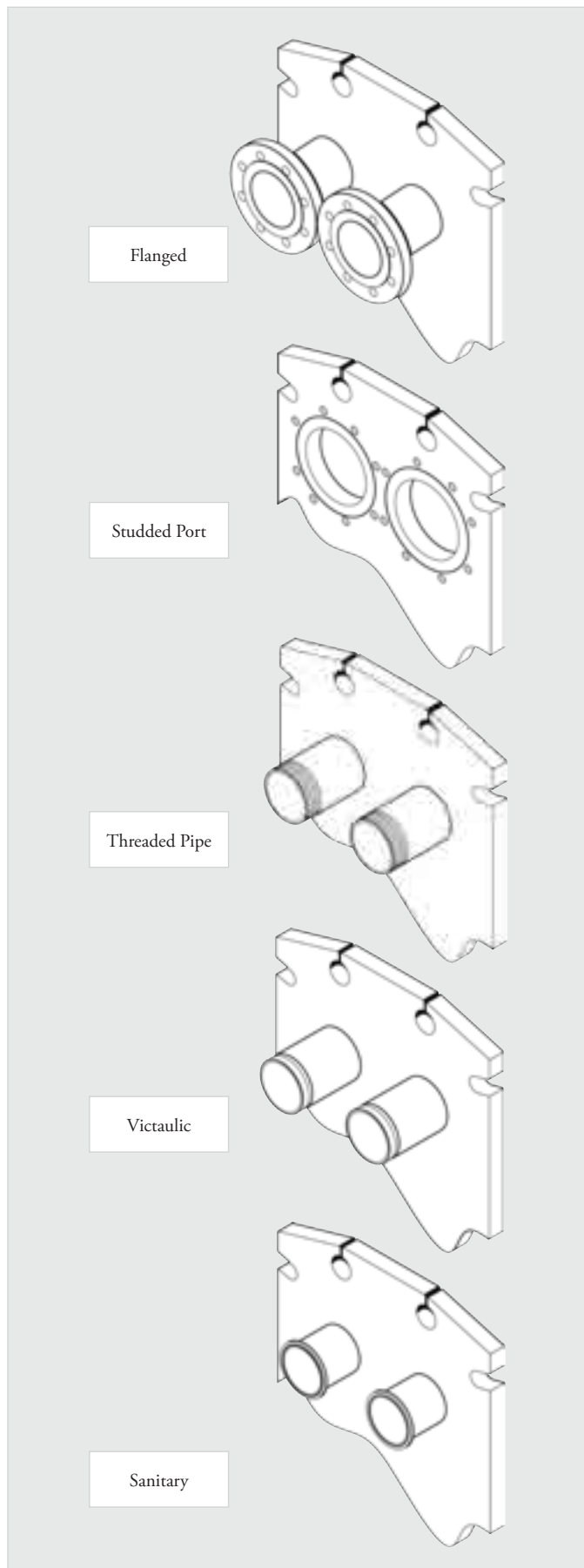
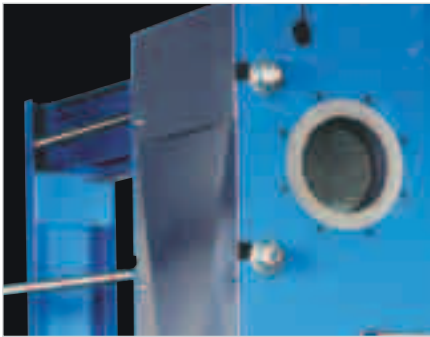

Plate Heat Exchanger Accessories



Shrouds

Shrouds provide insulation and protection in an aggressive environment.

Other accessories include:

- Backflush valves
- Wrenches
- Grounding lugs
- Molybdenum bolt coatings
- Tie-rod protectors
- HexWrap insulation
- Insulated shrouds



Instruments And Gauges

Special flanges are available with outlets for drainage and ventilation, pressure gauges and sensors.



Hydraulic Opening Devices

Hydraulic opening devices make disassembly and reassembly of the exchangers fast and easy. Most importantly, it is accurate, able to attain specified gasket compression.

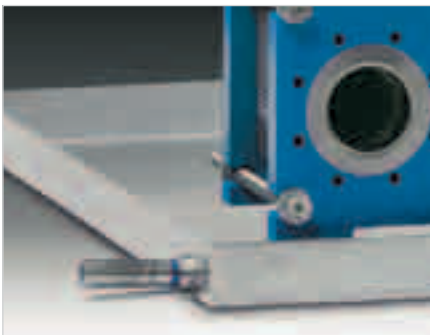

Drip Pans

Drip pans prevent water and other liquids from floating on to the floor when dismantling the heat exchanger.

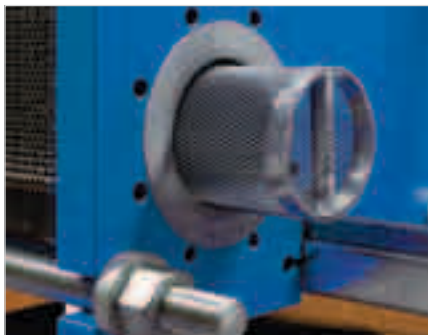

Port Strainers

A strainer protects the plate pack from large particles that would otherwise foul and clog the channels. The length is adapted to the number of plates.



Idea Notebook





Efficient Heat Transfer For Every Industry

Efficiency, cost effectiveness, high performance, minimal maintenance and service are demanded by every industry and commercial or governmental entity in today's highly competitive, technological world.

Plate & frame heat exchangers have demonstrated their superiority in satisfying these demanding needs over other types of heat exchangers—and the best of plate & frame are Tranter SUPERCHANGER units.

SUPERCHANGER heat exchangers are daily performing critical duties in a wide variety of applications around the world.

Stainless steel and high alloy plates in SUPERCHANGER units are performing extensive duties in chemical and petrochemical plants. Titanium plates on space saving shipboard units are being utilized in a variety of seawater cooling duties.

SUPERCHANGER units are effectively being used for electrolyte heating and cooling rolling mill coolants in a basic metals operation. Giant units are delivering efficient district cooling for office buildings in major metropolitan areas.

Heating, cooling and heat recovery applications in a wide array of industries include, but are not limited to:

- Automotive production
- Chemical processing
- Food processing
- HVAC operations
- Offshore oil & gas production
- Oil & gas processing
- Onboard marine vessels
- Power generation
- Steel & other metal production
- Pulp & paper mills
- Textile plants
- Pharmaceutical
- Mining
- Grain distilling



HVAC

Thousands of SUPERCHANGER heat exchangers are in HVAC service for “free cooling” and isolation purposes. “Free cooling” payback is typically less than one year.



Waste Heat Recovery

SUPERCHANGER heat exchangers recover heat very efficiently because of their high heat-transfer rates and close temperature approach capabilities.



Chiller Bypass “Free Cooling”

Two SUPERCHANGER units—installed in a bypass circuit so that the chillers can be shut down whenever outside temperatures drop below 45°F (7.2°C)—have reduced energy consumption up to 57% in a major Southeastern high-rise complex. Included in the complex is one hotel, two towers, three condominium buildings, one large mall and a number of small buildings.



Automotive

The large SUPERCHANGER units shown here cool closed-loop water, which is used in cooling automatic welding machines. Other major automotive applications are heating wash, phosphate and rinse solutions and temperature control of paint, plating solutions, etc.



Power Generation

Primary power applications involve cooling of condensate, turbine bearing oil, ash handling systems, oil sumps, etc. Many duties include secondary exchangers to a central cooling unit.



Pulp & Paper

Cooling bleach solutions, digester heat recovery, cooling white water and heat recovery from boiler blowdown are some of the numerous applications in the pulp & paper industry.



Food Processing

Pictured here is a SUPERCHANGER heat exchanger performing one of hundreds of duties in the food processing industry, which includes process heating or cooling (many with viscous fluids), basic water heating and heat recovery from waste streams.

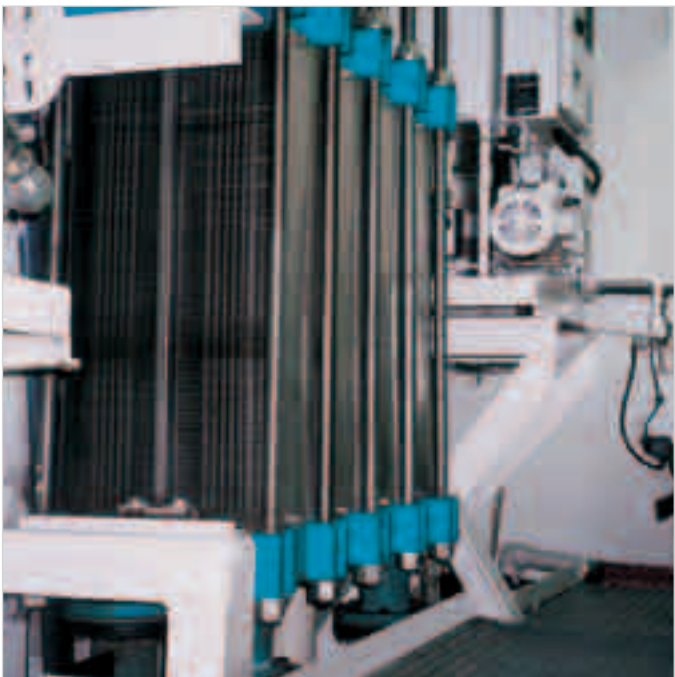

Maritime

SUPERCHANGER units installed nozzles down replace shell & tube exchangers as engine lube oil coolers on oceangoing tugboats, improving efficiency, saving weight and space, and reducing maintenance.





Saving Energy Through Waste Heat Recovery

Today's ethanol plants require a high degree of thermal integration technology. Heating and cooling of liquids is at the core of the ethanol production process. Capturing surplus process heat and reusing or redirecting it to other areas of the plant significantly reduces energy requirements and costs.

Your Tranter representative can survey all your waste heat streams and provide you with recovery feasibility models, prioritized for economic impact.

Opportunities include surplus and counterflowing heat streams from:

- Mash
- Beer
- Condensers
- Ethanol cooler
- Distillation column bottoms cooler
- Syrup condenser
- Dryer exhaust heat recovery
- Evaporators



Externally Heated Cooking

This cooking vessel uses an isolated heating fluid circuit with a SUPERCHANGER cook water heater. A second SUPERCHANGER, employed as an economizer/preheater within the circuit, uses low-grade surplus heat streams to reduce steam consumption in the cook water heater.



Dehydration

A SUPERCHANGER used as an economizer recovers energy from the processed fluid to pre-heat process media. The result is significantly less energy required to maintain the operation at optimum conditions. Other SUPERCHANGER units condense vapors and cool condensate from various processes.



Fermentation

A Wide-Gap SUPERCHANGER preheats beer while cooling mash as an economizer significantly reducing plant energy usage. A second Wide-Gap SUPERCHANGER works as a trim cooler to reduce the mash to fermentation temperature. A third SUPERCHANGER maintains optimal fermentation temperature for the fermentation tanks.



Evaporation

A Wide-Gap SUPERCHANGER cools distillation column bottoms prior to centrifuging. A PLATECOIL bank can be used as the steam-driven heat source for the column bottoms evaporator. A Wide-Gap SUPERCHANGER condenses syrup from the evaporator.





Other Tranter Plate Heat Exchanger Products And Services

Welded heat exchangers

Tranter's SUPERMAX® and MAXCHANGER® welded heat exchangers offer distinct advantages of plate heat transfer efficiency, due in large measure to the turbulent flow created by the corrugated patterns of their plates. Because of their high efficiency, Tranter welded units can handle temperature approaches of less than 2°F (1°C). Their smaller hold-up volume than shell & tube results in faster start-ups and closer following of process changes. Beyond efficiency, all three offer cost effectiveness, high performance and minimal maintenance.



SUPERMAX®

The SUPERMAX welded plate heat exchanger handles liquids, gases and two-phase mixtures at pressures to 1,000-plus psig (68-plus barg) and at very low and high temperatures. Nozzle sizes up to 18 in. (DN 450) can be accommodated on the shell side of the exchanger, offering higher steam and liquid flow rates. It can be fabricated from dissimilar metals when only one side will be exposed to corrosive conditions.



MAXCHANGER®

If prime application considerations include a variety of connection locations, space and single-material design, the MAXCHANGER is extremely versatile. It can be used in many duties where shell & tube units typically cool mechanical and electrical equipment—liquid-to-liquid, steam-to-liquid, gas-to-liquid, gas-to-gas and refrigerant applications (including ammonia).

PLATECOIL®

These versatile, highly efficient PLATECOIL® prime surface heat exchangers replace costly and unwieldy pipecoil, steam sparging or expensive resistance heating elements. High internal flow velocities of these exchangers generate effective heat transfer rates.

Tranter's exclusive Multi-Zone configuration—designed to uniformly deliver steam to all levels of the unit through zoned headers—and two Serpentine configurations are available in more

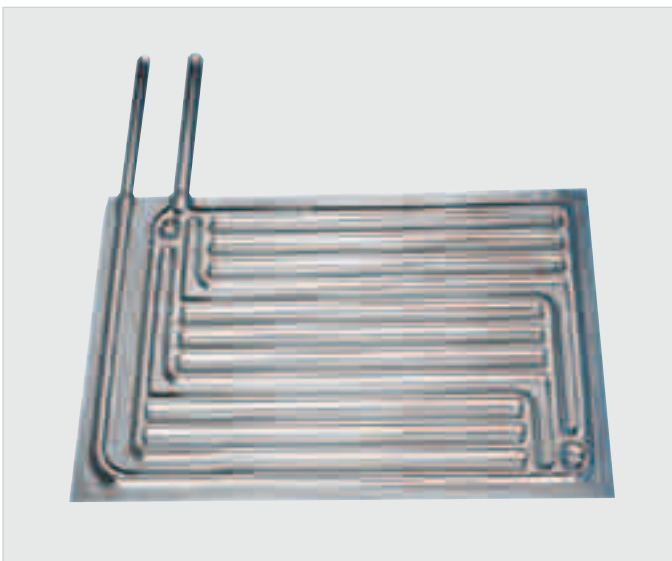

PLATECOIL®

than 300 standard sizes or can be custom designed. Single- and double-embossed styles may be flat, bent or rolled as immersion heaters, banked for tanks, used in mixers, cryogenic shrouds, jacketed vessels, clamp-on panels and a wide variety of other configurations.

Tranter spiral heat exchangers

Heating or cooling of particle-laden or viscous fluids is a difficult duty class for shell & tube exchangers. Spiral heat exchangers with their compact, single channel design are ideally suited for outstanding thermal and uptime performance in these duties. Spirals can attain high heat-transfer coefficients with particle-loaded fluids, while avoiding fouling or plugging.



The Tranter Spiral Heat Exchanger

The spiral heat exchanger's single flow channel is inherently self-cleaning and fouling-resistant, because flow cannot bypass an obstruction. As a result, the flow distribution within both channels remains even and steady throughout the exchanger. Temperature differences between the fluids of less than 3°C (5°F) can be reached. The shell & tube unit instead develops an uneven temperature profile caused by fouling, tube plugging and poor flow distribution, with both dead spots and eroded surfaces.

In particle-laden service, any heat exchanger must be installed with provision for ease of cleaning. Here, the compact and thermally efficient spiral, able to be cleaned virtually within its own physical footprint, has a tremendous advantage. Not only is the shell & tube of equivalent thermal duty much larger, but it also requires more than twice its installed footprint for the tube bundle to be pulled for cleaning. Thus in retrofit service, the compact spiral exchanger can be readily integrated within existing footprints with low installation costs.



Service Centers

At Tranter service centers, we safely clean and regasket your heat exchanger plates, returning them to peak efficiency, and guarantee our work with our own written warranties covering materials and workmanship.

We do pressure washing and chemical cleaning of plates, die penetrant testing to check plates for defects or pinholes, and regasketing with OEM gaskets matched via the nameplate database. Entire unit refurbishment includes frame repair (sandblasting and repainting), complete plate pack service, reassembly and closing the unit to precise factory specifications. We then carry out hydro testing of the unit and can confirm performance on-site to affirm process compatibility under changed conditions.

With Tranter and its authorized service facilities, you can always be sure that you get the right gaskets, the right plates, the friendliest service and our OEM Guarantee. Give us a call at (940) 723-7125.



Tranter Service Center (USA)

Factory/Sales/Engineering Office
1900 Old Burk Highway
Wichita Falls, TX 76306
Tel: 1-800-414-6908 • Fax: 940-723-5131
E-mail: aftermarket@tranter.com

Tranter Midwest Service Center (USA)

30241 Frontage Road
Farmersville, IL 62533
Tel: 217-227-3470
E-mail: service_il@tranter.com

Tranter Gulf Coast Service Center (USA)

6819 Willowbrook Park
Houston, TX 77066
Tel: 1-800-414-6908 • Fax: 713-467-1502
E-mail: service_hou@tranter.com

Tranter West Coast Service Center (USA)

857 E. Levin
Tulare, CA 93274
Tel: 559-686-1840 • Fax: 559-686-3964
E-mail: service_ca@tranter.com

Tranter East Coast Service Center (USA)

316 East 22nd Street
Norfolk, VA 23504
Tel: 757-533-9185 • Fax: 757-533-9186
E-mail: service_va@tranter.com

Tranter International AB (United Kingdom)

Wakefield Factory
Tranter Ltd, Unit 50
Monckton Road Industrial Estate
Wakefield WF2 7AL England
Tel: +44-1924 298 393 • Fax: +44-1924 219 596
E-mail: info@uk.tranter.com



Tranter International AB (Sweden)

Regementsgatan 32
PO Box 1325
SE-462 28 Vänersborg Sweden
Tel: +46 521 799 800 • Fax: +46 521 799 822
E-mail: info@se.tranter.com

Tranter International AB (Germany)

Käthe-Paulus-Strasse 9
Postfach 10 12 14
DE-31137 Hildesheim Germany
Tel: +49-512 175 2077 • Fax: +49-512 188 8561
E-mail: info@de.tranter.com

Tranter International AB (Italy)

Via Ercolano, 24
IT-20052 Monza MI Italy
Tel: +39-039 28 282 210 • Fax: +39-039 834 315
E-mail: info@it.tranter.com

Tranter, Latin America, S.A. de C.V.

Prolongación Tecnológico Nte. 148 Nave 25
Condominio Industrial el Fénix
Querétaro, México 76154
Tel: +52 (442) 217 44 98 * Fax: +52 (442) 210 11 27
E-mail: gscully@tranter.com

Tranter Ind e Com de Equip Ltda (Brazil)

Av. Maestro Manoel Vitorino dos Santos,
731, 06707-200, Cotia, SP Brazil
Tel/Fax: +55 11 3608-4154
E-mail: vendas@tranter.com

Tranter India Pvt. Ltd. (India)

Gat. No. 985, Sanaswadi Tal. Shirur
Dist.Pune -421 208 (India)
Tel: +91-2137-392300 • Fax: +91-2137-392354
E-mail: sales@in.tranter.com

Tranter Service Center (Canada)

4080-78 Avenue
Edmonton, AB T6B 3M8 Canada
Tel: 780-465-4582 • Fax: 780-469-5448
E-mail: servicecanada@tranter.com

SUPERCHANGER Fax Form

For an estimate, complete and fax this form to Tranter at (940) 723-1131. Items in **blue** should be completed for best estimate.

Data Required

| | |
|----------------------|---|
| Customer | Phone |
| Address | Fax |
| City, St, Zip | Project |
| Contact | Number of Units |
| Email | ASME Code Stamp: <input type="checkbox"/> Yes <input type="checkbox"/> No |

Design Conditions

Quantities entered in English or Metric (Check one)

| | Hot Side | Cold Side |
|---|--|--|
| Type Of Fluid | | |
| Flow Rate, gpm or lpm | | |
| Specific Heat, Btu/(lb) °F or Therm/(kg) °C | | |
| Specific Gravity | | |
| Thermal Conductivity, Btu/(hr)(ft) °F or Therm/(hr)(m) °C | | |
| Viscosity, Cp@ °F or Cp@ °C | | |
| 1st Temperature | | |
| 2nd Temperature | | |
| Temperature In, °F or °C | | |
| Temperature Out, °F or °C | | |
| Pressure Drop, psi or bar | | |
| Operating Pressure, psig or barg | | |
| Heat Exchanged, Btu/hr or Therm/hr | | |
| Design Pressure, psig or barg | Materials of Construction | |
| Test Pressure, psig or barg | Plates: <input type="checkbox"/> 304SS <input type="checkbox"/> 316SS | Gasket: <input type="checkbox"/> NBR <input type="checkbox"/> EPDM <input type="checkbox"/> Viton |
| Design Temperature, °F or °C | <input type="checkbox"/> Titanium | Other: _____ |
| | Other: _____ | |

Note: For fluids other than water or steam, properties should be furnished for FASTEST and most ACCURATE sizing.



At the forefront of heat exchanger technology for more than 70 years

Tranter top quality, high-performance, proprietary products are on the job in demanding industrial and commercial installations around the world. Backed by our comprehensive experience and worldwide presence, Tranter offers you exceptional system performance, applications assistance and local service. Tranter is close to its customers, with subsidiary companies, agents, distributors and representatives located worldwide. Contact us for a qualified discussion of your needs.



North America
Tranter, Inc.
Wichita Falls, TX USA
Tel: (940) 723-7125
Fax: (940) 723-5131
E-mail: sales@tranter.com

Mexico
Tranter LA de CV
Querétaro, México 76154
Tel: +52 (442) 217 44 98
Fax: +52 (442) 210 11 27
E-mail: gscully@tranter.com

Europe
Tranter International AB
Vänernborg, Sweden
Tel: +46 521 799 800
Fax: +46 521-673 93
E-mail: info@se.tranter.com

Mid-East/Africa/Asia
Tranter India Pvt. Ltd.
Pune, India
Tel: +91 20-30519300
Fax: +91 20-30519350
E-mail: sales@in.tranter.com

South America
Tranter Ind e Com de Equip. Ltda
Cotia, Brazil
Tel: +55 11 36084154
E-mail: vendas@tranter.com

China/Southeast Asia
Tranter China
Beijing, China
Tel: +86 10 6554 4920/21
E-mail: paulyang@tranter.com.cn
Support: tina@tranter.com.cn

www.tranter.com

Tranter, Inc. also manufactures PLATECOIL® prime surface, MAXCHANGER® compact welded plate and SUPERMAX® shell and plate heat exchangers.